





Plant PPU & CDW	Client IOCL, PANIPAT REFINERY	Contract Code RHQ, EPCM-3 (P-25)	Document ID 6746-INS-022-EC-0130	Contract No. 66-6746	
	TECHNICAL SPECIFICATIONS – ULTRASONIC FLOWMETERS-INLINE (INSERTION) TYPE				
	Rev	00	Page		0

<p>tkIS India / Vendor</p> <table style="width: 100%;"> <tr><td style="width: 15%;">Category Codes (Submission Purpose)</td><td style="width: 5%;"><input type="checkbox"/></td><td style="width: 5%;">1</td><td>For Approval</td></tr> <tr><td></td><td><input type="checkbox"/></td><td>2</td><td>For Review / Comments</td></tr> <tr><td></td><td><input type="checkbox"/></td><td>3</td><td>For Information</td></tr> <tr><td></td><td><input type="checkbox"/></td><td>4</td><td>For Engineering</td></tr> <tr><td></td><td><input type="checkbox"/></td><td>5</td><td>For Enquiry</td></tr> <tr><td></td><td><input type="checkbox"/></td><td>6</td><td>For Order Placement</td></tr> <tr><td></td><td><input type="checkbox"/></td><td>7</td><td>Final & Approved</td></tr> <tr><td></td><td><input type="checkbox"/></td><td>8</td><td>Released for Construction</td></tr> </table> <hr/> <table style="width: 100%;"> <tr><td style="width: 15%;">Acceptance Codes (Approval Codes)</td><td style="width: 5%;"><input type="checkbox"/></td><td style="width: 5%;">1</td><td>Approved</td></tr> <tr><td></td><td><input type="checkbox"/></td><td>2</td><td>Approved for Manufacturing / Fabrication with Comments as marked</td></tr> <tr><td></td><td><input type="checkbox"/></td><td>3</td><td>Not Approved / Resubmit</td></tr> <tr><td></td><td><input type="checkbox"/></td><td>4</td><td>Retained for Information / Records</td></tr> <tr><td></td><td><input type="checkbox"/></td><td>5</td><td>Reviewed</td></tr> <tr><td></td><td><input type="checkbox"/></td><td>6</td><td>Reviewed as Noted / Resubmit</td></tr> </table> <p>Remarks for AC2 : This marked-up drawings is hereby approved for fabrication / manufacturing and shall be re-submitted after revision. This drawing should be revised only to the extent of tkIS India / Owner / Client comments. Any other changes made by you will not be considered unless clearly highlighted in covering letter asking for approval.</p> <p>This approval / review does not absolve the supplier from the full responsibility for design and fabrication.</p> <p>Date : ___/___/___ Name : _____</p>	Category Codes (Submission Purpose)	<input type="checkbox"/>	1	For Approval		<input type="checkbox"/>	2	For Review / Comments		<input type="checkbox"/>	3	For Information		<input type="checkbox"/>	4	For Engineering		<input type="checkbox"/>	5	For Enquiry		<input type="checkbox"/>	6	For Order Placement		<input type="checkbox"/>	7	Final & Approved		<input type="checkbox"/>	8	Released for Construction	Acceptance Codes (Approval Codes)	<input type="checkbox"/>	1	Approved		<input type="checkbox"/>	2	Approved for Manufacturing / Fabrication with Comments as marked		<input type="checkbox"/>	3	Not Approved / Resubmit		<input type="checkbox"/>	4	Retained for Information / Records		<input type="checkbox"/>	5	Reviewed		<input type="checkbox"/>	6	Reviewed as Noted / Resubmit	<p>tkIS India / Owner / Client</p> <table style="width: 100%;"> <tr><td style="width: 15%;">Category Codes (Submission Purpose)</td><td style="width: 5%;"><input type="checkbox"/></td><td style="width: 5%;">1</td><td>For Approval</td></tr> <tr><td></td><td><input type="checkbox"/></td><td>2</td><td>For Review / Comments</td></tr> <tr><td></td><td><input type="checkbox"/></td><td>3</td><td>For Information</td></tr> <tr><td></td><td><input type="checkbox"/></td><td>4</td><td>For Engineering</td></tr> <tr><td></td><td><input checked="" type="checkbox"/></td><td>5</td><td>For Enquiry</td></tr> <tr><td></td><td><input type="checkbox"/></td><td>6</td><td>For Order Placement</td></tr> <tr><td></td><td><input type="checkbox"/></td><td>7</td><td>Final & Approved</td></tr> <tr><td></td><td><input type="checkbox"/></td><td>8</td><td>Released for Construction</td></tr> </table> <hr/> <table style="width: 100%;"> <tr><td style="width: 15%;">Acceptance Codes (Approval Codes)</td><td style="width: 5%;"><input type="checkbox"/></td><td style="width: 5%;">1</td><td>Approved</td></tr> <tr><td></td><td><input type="checkbox"/></td><td>2</td><td>Approved for Manufacturing / Fabrication with Comments as marked</td></tr> <tr><td></td><td><input type="checkbox"/></td><td>3</td><td>Not Approved / Resubmit</td></tr> <tr><td></td><td><input type="checkbox"/></td><td>4</td><td>Retained for Information / Records</td></tr> <tr><td></td><td><input type="checkbox"/></td><td>5</td><td>Reviewed</td></tr> <tr><td></td><td><input type="checkbox"/></td><td>6</td><td>Reviewed as Noted / Resubmit</td></tr> </table> <p>Date : ___/___/___ Name : _____</p>	Category Codes (Submission Purpose)	<input type="checkbox"/>	1	For Approval		<input type="checkbox"/>	2	For Review / Comments		<input type="checkbox"/>	3	For Information		<input type="checkbox"/>	4	For Engineering		<input checked="" type="checkbox"/>	5	For Enquiry		<input type="checkbox"/>	6	For Order Placement		<input type="checkbox"/>	7	Final & Approved		<input type="checkbox"/>	8	Released for Construction	Acceptance Codes (Approval Codes)	<input type="checkbox"/>	1	Approved		<input type="checkbox"/>	2	Approved for Manufacturing / Fabrication with Comments as marked		<input type="checkbox"/>	3	Not Approved / Resubmit		<input type="checkbox"/>	4	Retained for Information / Records		<input type="checkbox"/>	5	Reviewed		<input type="checkbox"/>	6	Reviewed as Noted / Resubmit
Category Codes (Submission Purpose)	<input type="checkbox"/>	1	For Approval																																																																																																														
	<input type="checkbox"/>	2	For Review / Comments																																																																																																														
	<input type="checkbox"/>	3	For Information																																																																																																														
	<input type="checkbox"/>	4	For Engineering																																																																																																														
	<input type="checkbox"/>	5	For Enquiry																																																																																																														
	<input type="checkbox"/>	6	For Order Placement																																																																																																														
	<input type="checkbox"/>	7	Final & Approved																																																																																																														
	<input type="checkbox"/>	8	Released for Construction																																																																																																														
Acceptance Codes (Approval Codes)	<input type="checkbox"/>	1	Approved																																																																																																														
	<input type="checkbox"/>	2	Approved for Manufacturing / Fabrication with Comments as marked																																																																																																														
	<input type="checkbox"/>	3	Not Approved / Resubmit																																																																																																														
	<input type="checkbox"/>	4	Retained for Information / Records																																																																																																														
	<input type="checkbox"/>	5	Reviewed																																																																																																														
	<input type="checkbox"/>	6	Reviewed as Noted / Resubmit																																																																																																														
Category Codes (Submission Purpose)	<input type="checkbox"/>	1	For Approval																																																																																																														
	<input type="checkbox"/>	2	For Review / Comments																																																																																																														
	<input type="checkbox"/>	3	For Information																																																																																																														
	<input type="checkbox"/>	4	For Engineering																																																																																																														
	<input checked="" type="checkbox"/>	5	For Enquiry																																																																																																														
	<input type="checkbox"/>	6	For Order Placement																																																																																																														
	<input type="checkbox"/>	7	Final & Approved																																																																																																														
	<input type="checkbox"/>	8	Released for Construction																																																																																																														
Acceptance Codes (Approval Codes)	<input type="checkbox"/>	1	Approved																																																																																																														
	<input type="checkbox"/>	2	Approved for Manufacturing / Fabrication with Comments as marked																																																																																																														
	<input type="checkbox"/>	3	Not Approved / Resubmit																																																																																																														
	<input type="checkbox"/>	4	Retained for Information / Records																																																																																																														
	<input type="checkbox"/>	5	Reviewed																																																																																																														
	<input type="checkbox"/>	6	Reviewed as Noted / Resubmit																																																																																																														

PIN-OMC-03-F101 08-2017

00	IFI	For Enquiry	24.07.25	VPK	24.07.25	RJK	24.07.25	RJK	01
Rev.	Status	Description	Date	Prepared	Date	Checked	Date	Approved	AC
Based on : PIN-LES-INS-032 08-2017					Barcode				
© Copyright 2017 : All rights reserved. thyssenkrupp Uhde India Private Limited					Category Code: -5				



Plant PPU & CDW	Client IOCL, PANIPAT REFINERY	Contract Code RHQ, EPCM-3 (P-25)	Document ID 6746-INS-022-EC-0130	Contract No. 66-6746	
	TECHNICAL SPECIFICATIONS – ULTRASONIC FLOWMETERS INLINE (INSERTION) TYPE				
	Rev	00	Page		1

CONTENTS:

NO.	DESCRIPTION	PAGE NOS.
1.	Standard general specification – Ultrasonic Flowmeters INLINE (INSERTION) TYPE	2 ~ 4
2.	Project specific requirements	5 ~ 8
3.	Inspection and testing requirements	9 ~ 11
4.	Documentation requirements	12 ~ 13
5.	Compliance Declaration & Deviation list format	14~ 15
6.	Tag List – Ultrasonic Flowmeters	I1
7.	Data Sheets – Ultrasonic Flowmeters	S1

DOCUMENTS ATTACHED:

NO.	DESCRIPTION	NO. OF PAGES	DOCUMENT NO.	LATEST REV.
1.	Technical Requirements for pipe, Fitting, Flanges, Gaskets & fasteners	11	6746-PIP-000-EC-0005	00
2.	Technical requirement for Hydrogen service	3	RHQ-EC-ML-0001 2021 page 36 to 38 of 94	00
3.	Piping specification – A4A, A1K	4	A4A,A1K	00
4.	Standard Specification for Positive material identification (PMI)	6	6-81-001	00
5.	Vendor Documentation Procedure	15	6746-PDM-000-BD-0002	00
6.	Vendor Coordination Procedure	14	6746-PMG-000-BD-0004	00

Plant PPU & CDW	Client IOCL, PANIPAT REFINERY	Contract Code RHQ, EPCM-3 (P-25)	Document ID 6746-INS-022-EC-0130	Contract No. 66-6746	
	TECHNICAL SPECIFICATIONS – ULTRASONIC FLOWMETERS INLINE (INSERTION) TYPE				
				Rev	00

STANDARD GENERAL SPECIFICATION - ULTRASONIC FLOWMETERS INLINE (INSERTION) TYPE

1.0 GENERAL

This specification covers the general requirements of Ultrasonic Flow meters. Detailed specifications are as per the individual data sheets attached.

The order of precedence in case of conflict should be

1. Individual data sheets
2. Project specific requirement
3. Standard General Specification

The documents attached with this document form integral part of the specifications and shall be read in conjunction with this document.

4. In case of any discrepancy between the above documents, vendor to bring it to the notice of tkIS/ IOCL for the resolution. In general most stringent requirement shall be applicable.

Ambient conditions for site are as below:

Temperature (o C) - Max 48 / Min. (-) 0.7, normal: 30

Relative Humidity (%) Normal 36% @45 Deg C, max: 90% @48 Deg C

Hazardous area classification



Zone1, IIC, T3

The offered instrument shall be suitable for the above conditions

2.0 TYPE AND CONSTRUCTION

2.1 Metering Tube

- 2.1.1 Metering tube body casting shall be free from blowholes, porosity, cracks and other defects. Repairs of any nature on such defects are not acceptable.
- 2.1.2 Meter connection for inline flowmeters shall be flanged. Refer individual data sheet for size and pressure rating. Sandwich type connection is not acceptable.
- 2.1.3 The seller shall determine the number and location of transducers necessary to meet the requirements of accuracy, repeatability as stated on the Instrument Data Sheet. Spool piece assemblies shall be flanged, and of the same size and internal bore as the Purchaser's pipe, unless otherwise specified on the Instrument Data Sheet.
- 2.1.4 The Ultrasonic Flowmeter transducers (probes) may be mounted externally on the pipe, or furnished with a spool piece assembly, as specified on the Instrument Data Sheet. Spool piece assemblies shall be flanged, and of the same size and internal bore as the Purchaser's pipe, unless otherwise specified on the Instrument Data Sheet.
- 2.1.5 The transducers shall be replaceable under pressure.

Plant PPU & CDW	Client IOCL, PANIPAT REFINERY	Contract Code RHQ, EPCM-3 (P-25)	Document ID 6746-INS-022-EC-0130	Contract No. 66-6746	
	TECHNICAL SPECIFICATIONS – ULTRASONIC FLOWMETERS INLINE (INSERTION) TYPE				
				Rev	00

- 2.1.6 The meter design shall be suitable for flow in either direction without reduction in performance, if specified on the Instrument Data Sheets.
- 2.1.7 Spare cable entries in the transmitter housing shall be plugged with stainless steel plugs.



2.2 Transmitter

- 2.2.1 In case the transmitter is separately mounted (not integral with metering tube), 20m of special signal cable between metering tube and transmitter with necessary cable glands, mounting brackets etc. shall be supplied along with each instrument.
- 2.2.2 Spare cable entries in the transmitter housing shall be plugged with stainless steel plugs.
- 2.2.3 Output signal from transmitter shall be fully isolated from power supply and input signal from metering tube.
- 2.2.4 The Ultrasonic Flowmeter assembly shall not be effected by external process plant generated vibrations, noise, or changes in process conditions within the design parameters specified on the Instrument Data Sheets.
- 2.2.5 The meter electronics shall be immune to RFI and EMI radiation and shall be in compliance with the electromagnetic compatibility requirement as per IEC 61000-4.
- 2.2.6 In case intelligent (SMART) transmitters are specified, a suitable device for configuring the same is included in scope of supply.
- 2.2.7 Transmitter shall be compliant to NAMUR NE43 requirement.
- 2.2.8 All instruments shall be tropicalized.
- 2.2.9 Ultrasonic flow meter electronics shall have provision for 2 nos. analog inputs (from external PT and TT) for absolute pressure & absolute temperature corrections shall be provided for compensation/ accurate measurement of flow(volume, mass & molecular weight).

3.0 IDENTIFICATION

- 3.1 Each flow meter (metering tube and transmitter wherever the same are separate) shall be provided with the following details engraved on a tag-plate. The tag-plate shall be permanently fixed to the metering tube/ transmitter.

- a. Manufacturer's name.
- b. Model number.
- c. Serial number.

Plant PPU & CDW	Client IOCL, PANIPAT REFINERY	Contract Code RHQ, EPCM-3 (P-25)	Document ID 6746-INS-022-EC-0130	Contract No. 66-6746	
	TECHNICAL SPECIFICATIONS – ULTRASONIC FLOWMETERS INLINE (INSERTION) TYPE				
				Rev	00

- d. Tag number. This shall be available on metering tube as well as transmitter.
- e. Calibrated range.
- f. Meter constant.
- g. Flameproof certification (if applicable).
- h. Power supply.
- i. Meter size and pressure rating. This shall be punched on the meter tube/flange.

4.0 INFORMATION REQUIRED WITH THE BID



4.1 Vendor shall submit the following with the bid.

- a. Catalogues/literature for all models offered including sizing data.
- b. Upstream/downstream straight run piping requirement for each tag.
- c. Pressure drop across the meter @normal and maximum flow rates.
- d. Flameproof certification and Approval of Chief Controller of Explosives (CCoE), Petroleum and Explosives Safety Organization (PESO), wherever applicable.
- e. Spare parts required for two years continuous trouble-free operation.
- f. Commissioning spares
- g. Compliance declaration

5.0 SPECIAL REQUIREMENTS

5.1 Vendor shall ensure that metering tube shall be selected as per following criteria:

- a. Accuracy specified shall be achieved for minimum velocity of 0.5 m/s for liquid and gases.
- b. Velocity through meter body @ maximum flow shall be restricted to 15m/s for liquid and 30m/s for gases.
- c. For custody transfer meter; upstream/downstream straight runs of pipe and flow profile plate is required to achieve accuracy and repeatability are include in seller scope of supply.
- d. Meter shall be calibrated in accredited Flow Lab.

Plant PPU & CDW	Client IOCL, PANIPAT REFINERY	Contract Code RHQ, EPCM-3 (P-25)	Document ID 6746-INS-022-EC-0130	Contract No. 66-6746
	TECHNICAL SPECIFICATIONS – ULTRASONIC FLOWMETERS INLINE (INSERTION) TYPE			
	Rev	00	Page	



PROJECT SPECIFIC REQUIREMENTS – ULTRASONIC FLOWMETERS INLINE (INSERTION) TYPE

Following specification covers the project specific requirements:



The order of precedence in case of conflict should be

1. Individual data sheets
2. Project specific requirement
3. Standard General Specification



Sr. No.	STD GS Clause No.	Project specific requirements	Remarks
1	General	<p><u>Applicable codes and Standards</u> Instrumentation Codes/ References Standards for the designand Installation of Instrumentation system shall comply with the standards and codes for the specific subjects. The related standards referred to herein and mentioned below shall be ofthe latest edition prior to the date of purchaser’s enquiry. Following codes, standard practices and references shall be applicable:</p> <ol style="list-style-type: none"> 1. ASME B16.5 :Steel Pipe Flanges and Flanged Fittings 2. ASME B 16.20 :Metallic Gaskets for Pipe Flanges, RingJoint, Spiral Wound and Jacketed 3. ANSI/ASME B 1.20.1 General-purpose threads 4. IEC 60079 Electrical Apparatus for Explosive GasAtmosphere 5. IEC 60529 Degree of Protection ProvidedbyEnclosures 6. IEC 60529: Mechanical protection degree of enclosures(IP code) 7. IEC 60079 Electrical Apparatus for Explosive Gas atmosphere 8. IEC 61508: Functional safety of electrical/electronic/ programmable electronic safety-related systems. General requirements 9. IEC 61511: Safety instrumented systems for the process industry sector. 10. IBR: Indian Boiler regulation 11. NACE MR0175/ ISO 15156> Petroluem and Natural Gas industries- Material for use of H2S –Containing environments in Oil and Gas Production. 12. NACE MR0103: Materials resistant to Sulphide StressCracking in Corrosive Petroleum Refining Environments 13. MPMS:Manual of Petroleum measurement standards. SAMA Scientific Apparatus Association. 14. OISD-STD-152- Safety System Instrumentation for Process in HC Industry. 	

Plant PPU & CDW	Client IOCL, PANIPAT REFINERY	Contract Code RHQ, EPCM-3 (P-25)	Document ID 6746-INS-022-EC-0130	Contract No. 66-6746	
	TECHNICAL SPECIFICATIONS – ULTRASONIC FLOWMETERS INLINE (INSERTION) TYPE				
	Rev	00	Page		6



2	<p><u>Flow meter Body:</u></p> <ul style="list-style-type: none"> -The Ultrasonic flow meter shall be based on transit time technology. -The flow meter transducers shall be energized by the integral electronics to transmit and receive ultrasonic waves. - Type of transducer shall be Acoustically impedance matched, high Curie point, Piezoelectric element. -The meter design shall have the facility to remove /replace the transducers in situ under line operating condition. Failure or removal of one pair of transducers shall not cause the meter to lose all measurement function. Failure of any path shall generate an alarm identifying the affected path. Also transducers ports shall be designed in a way to reduce the possibility of liquid or solid accumulation. -It shall be possible to replace transducers without a change in meter performance. After replacement of transducers and a possible change of the associated software constants, the resulting shift in the meter's performance should not be more than the allowable repeatability of the meter. -The vendor shall comprehensively advise the impact of transducer failure on the performance and accuracy of the Ultrasonic flow meter. Ultrasonic flow meters shall be rated for the maximum design pressure as indicated in the data sheets. -Ultrasonic flow meter spool inside diameter (ID) shall meet the specified pipe ID and internal surface roughness shall be as per API standard. -The flowmeter shall be suitable for horizontal & vertical mounting. However, the flow direction shall be clearly stamped or cast on the body.
3	<p>Meter Sizing:</p> <ul style="list-style-type: none"> -All the calculations and units of measurement shall be in metric standard only. -Ultrasonic flow meter shall be suitable for measuring flow with specified accuracy for velocity range from 0.3 m/s to 120 m/s, however, the flow measurement corresponding to 0.03 m/sec shall be detectable without ascertaining the accuracy. -Vendor shall furnish the sizing calculations to justify the selection of Ultrasonic flow meters considering the density and viscosity of the fluid. Selected meter size shall ensure that flow meter operates within 85% of their standard range (not extended). -Overall pressure loss across the meter assembly shall be within the permissible pressure loss specified in data

Plant PPU & CDW	Client IOCL, PANIPAT REFINERY	Contract Code RHQ, EPCM-3 (P-25)	Document ID 6746-INS-022-EC-0130	Contract No. 66-6746	
	TECHNICAL SPECIFICATIONS – ULTRASONIC FLOWMETERS INLINE (INSERTION) TYPE				
	Rev	00	Page		7



		<p>sheet. Pressure drop calculation across the meter shall be furnished.</p> <p>-Unless otherwise specified in the data sheets, vendor to ensure the velocity in the Ultrasonic flowmeter shall not exceed maximum permissible velocity.</p> <p>-Vendor shall indicate the range of viscosities over which the measurement accuracy remains within limits.</p> <p>- Ultrasonic flowmeters shall be suitable for measuring the flow with the specified accuracy with upstream and downstream straight length of 10D and 5D respectively for both process and flare application. Required calibration analysis to establish the specified performance shall be carried out by the vendor and included in their offer.</p>	
4		<p>Meters in Flare Applications / inline meters:</p> <p>-The ultrasonic flow meters shall be supplied in completely assembled condition with all the probes sensor/transducer, nozzles installation on a spool piece.</p> <p>- The number of probes required for a particular application and probe configuration shall be decided by the vendor. The same shall be decided such that measurement is considered across two acoustic paths as a minimum for flare applications.</p> <p>- For Inserion type sensor / receiver:</p> <p>a) The material of construction of all the wetted portions of probe shall be suitable for the specified process conditions.</p> <p>b) for process application, The probes shall be inserted through flanged nozzles of minimum 2" 300# size to ensure insertion and removal of probes. Threaded nozzles for insertion shall not be acceptable.</p> <p>For other application, vendor standard process connection for probe is acceptable. However, vendor to ensure sensor shall be online replacable.</p> <p>c) It shall be possible to insert or retract the probes on-line without process interruption. Suitable retraction assembly shall be supplied for insertion and removal of probes on-line. In case of Flare meters, Vendor shall mandatorily provide full bore ball valve for isolation for each transducer /probe. The location of probes shall be selected to avoid fouling.</p> <p>-For high temperature application, suitable arrangement shall be provided to protect the sensor from high temperature. Any additional mounting accessory, if necessary shall be supplied by vendor.</p>	

Plant PPU & CDW	Client IOCL, PANIPAT REFINERY	Contract Code RHQ, EPCM-3 (P-25)	Document ID 6746-INS-022-EC-0130	Contract No. 66-6746
	TECHNICAL SPECIFICATIONS – ULTRASONIC FLOWMETERS INLINE (INSERTION) TYPE			
				Rev 00 Page 8 of 19



		<p>-Ultrasonic signal frequency shall be dependent on the application. Accordingly, vendor to select suitable piezo-crystal probes meeting the specified requirements.</p>	
5		<p>Meter Electronics:</p> <p>-Ultrasonic flow meter's electronics system including power supplies, microcomputer, signal processing components and ultrasonic transducer excitation circuits, may be housed in common enclosures mounted remotely to the flowmeter and is referred to as the Signal Processing Unit (Transmitter). It shall be designed and installed to meet the specified hazardous area classification.</p> <p>-The transmitter/ signal processing unit shall be microprocessor-based electronics suitable for installation in the field under the ambient condition specified. Meter electronics shall be Weather proof to IP 65 and flameproof certified suitable to install in area classification. All field mounted items shall have enclosures suitable for the area classification indicated in purchaser's data.</p> <p>-The transmitter/ signal processing shall have extensive diagnostic capability. Self-diagnostic feature should include monitoring the health of the transducers and signal quality. Meter parameters and factors set into the meter electronics shall be retained in non-volatile memory and shall be secured with password such that un-authorized changes are prohibited.</p> <p>Configuration software and firmware shall be provided.</p> <p>-For transmitter/ signal processing, vendor shall ensure that the input/output signals and performance characteristics of individual instruments are compatible with each other.</p> <p>-The transmitter/ signal processing shall accept inputs from probes either directly or through pre-amplifier. The number of inputs shall be based on the number of paths selected for particular application.</p> <p>-The transmitter/ signal processing shall also accept inputs (4-20mA) from pressure, temperature for accurate measurement at operating conditions.</p> <p>-The cable entry sizes between the transmitter/ signal processing unit and pre-amplifier/transducers shall be decided by vendor. All interconnecting cables including Weatherproof & flameproof cable glands shall be supplied by vendor accordingly.</p> <p>- Transmitter/ signal processing output signals from the meter electronics shall be without flying leads. Number of cable entries and their sizes for the output signals shall be as per purchaser's datasheets.</p> <p>- Transmitter/ signal processing shall be capable of providing the following output signals (as applicable):</p>	

Plant PPU & CDW	Client IOCL, PANIPAT REFINERY	Contract Code RHQ, EPCM-3 (P-25)	Document ID 6746-INS-022-EC-0130	Contract No. 66-6746
	TECHNICAL SPECIFICATIONS – ULTRASONIC FLOWMETERS INLINE (INSERTION) TYPE			
	Rev	00	Page	



		<p>a) 4-20 mA outputs for Mass flow rate (Kg/h), as per the requirements mentioned in the purchaser's datasheets.</p> <p>b) One number single serial link (RS485) port shall be provided in transmitter/ signal processing unit for connecting all signals (including velocity (m/s), mass flowrate (kg/hr), volume flowrate (Nm3/hr), molecular wt, pressure (kg/cm2 g), temperature(°C), sound speed (m/s), fault & flow alarms to Purchaser's host system. Protocol shall be MODBUS RTU. Vendor shall furnish I/O mapping details, addresses etc. during detail engineering.</p>	
6		<p>Terminal Housing:</p> <p>-Meter electronics shall operate on 110V AC \pm 10%, 50 Hz \pm 3Hz UPS and shall be protected from overload and from transients.</p> <p>Low power consumption is desired. Supply voltage fluctuation of \pm 10 percent from the specified value and supply frequency fluctuation of \pm 3 Hz from the specified value shall not affect the meter performance.</p> <p>-The design of electronic instruments shall be in compliance with the electromagnetic compatibility requirements as per IEC61000-4.</p> <p>-The meter transducers shall be certified suitable for the specified area classification and weather proof to IP65. The transducer/sensor housing shall be flameproof (Ex d) certified suitable for the specified area classification.</p>	
7	--	<p>All transmitters/instruments shall be intrinsically safe, and shall be certified for use in the specified hazardous area classification by any recognized authority like CMRS, FM, CENELEC,PTB, BASSEFA etc.</p> <p>All intrinsically safe and explosion proof instruments and accessories shall in addition to the approvals by any of the above agencies have the certification of Petroleum and Explosives Safety Organisation (PESO), earlier known as CCOE, Nagpur, India. This is a mandatory requirement.</p>	
8		<p>Transmitter/ signal processing unit shall be remote 2" pipe / Frame mounted. Housing material shall be epoxy coated die cast aluminium. Integral display is required. Special armoured cable of 20 m between preamplifier/ trasducers and Transmitter shall be in vendor scope of supply.</p> <p>SS316 mounting bracket required in case of 2" pipe mounting to be supplied by the vendor.</p> <p>Vendor to provide min. 5 no's. of 1/2"NPTF cable entries for customer cable connections (i.e. for signal, power, RS485, PT & TT). If required suitable adaptors to be provided by vendor. In case of limitations w.r.t. number of cable entries in trasmitter, suitable J.B. along with cable, cable</p>	

Plant PPU & CDW	Client IOCL, PANIPAT REFINERY	Contract Code RHQ, EPCM-3 (P-25)	Document ID 6746-INS-022-EC-0130	Contract No. 66-6746	
	TECHNICAL SPECIFICATIONS – ULTRASONIC FLOWMETERS INLINE (INSERTION) TYPE				
	Rev	00	Page		10



		glands between Transmitter & intermediate J.B. shall be provided by vendor. Cables shall be PVC insulated, flame retardant & low smoke type, individual & overall shielded with drain wire & armoured as per IEC 60332 Cat. A.	
9	--	Transmitters shall be SMART (HART) type with 4-20 mA intrinsically output and shall be furnished with test terminals and bypass diode to facilitate field testing without disconnection of integral indicator. Instrument enclosure shall be designed with a dual compartment housing that provides metallic isolation between the electronics and the terminal compartments. The transmitter electronics shall be capable of monitoring their performance during normal operation. The transmitter diagnostics shall be able to detect both an input sensor failure and transmitter electronics failure. The sensor &/or electronics failure shall be transmitted to the host system (e.g. DCS/ESD). The transmitters shall have zero and range adjustable, and it shall be specified so that the normal operating value is within 40% to 70% of the calibrated range. Flow meter shall be SIL certified as indicated in datasheet for applicable tags. Transmitter housing shall be explosion proof with intrinsically safe output suitable to area classification defined.	
10	--	All electronic instrumentation shall be immune to the effects of electromagnetic interference from portable radio transmitters/receivers in the frequency range between 20 to 1000 MHz, which have magnetic field strength. RFI interference shall comply with the requirements of IEC 60801-3 (Electromagnetic Compatibility of Industrial process control equipment).	
11	--	All instruments shall be tropicalized to eliminate mildew, fungi, and other detrimental effects of a tropical environment. Packaging shall be suitable for shipment and storage under tropical conditions. All field equipment shall be suitable for operation in a corrosive, salt laden, marine atmosphere.	
12	--	Transmitter shall be provided with surge / lightning protection	
13	--	The degree of protection for instrument enclosures shall be in accordance with IEC 60529. The minimum degree of protection shall be IP65.	
14	--	All instruments wetted parts shall be SS316 as minimum and Electronic housing material shall be of Epoxy coated die cast Aluminium.	
15	--	The instrument pressure rating shall comply with the requirements of the piping class specification, with the	

Plant PPU & CDW	Client IOCL, PANIPAT REFINERY	Contract Code RHQ, EPCM-3 (P-25)	Document ID 6746-INS-022-EC-0130	Contract No. 66-6746	
	TECHNICAL SPECIFICATIONS – ULTRASONIC FLOWMETERS INLINE (INSERTION) TYPE				
	Rev	00	Page		11

		exception that a minimum rating of ANSI class 300# shall be provided.	
16	--	External UPS power supply of 110VAC, 50 Hz shall be available for all flowmeters.	
17	--	Cable glands required for special cable between sensor and transmitter shall be supplied by vendor. Cable glands and plugs MOC shall be SS304 as minimum. Cable glands shall comply with BS6121 part 1. All instrument cable glands shall double compression type with dual certified Exe/ Exd. All gland installations shall maintain the IP rating of the associated equipment. Cable glands in the field shall be protected by fitting (PVC) plastic shrouds with silicon grease; shrouds to be zero halogen and oil resistant	
18	--	Mounting brackets suitable for 2" vertical pipe mounting for transmitter shall be supplied by vendor. MOC shall be SS304 min.	
19	--	Vendor shall configure the transmitter with all the data as per the datasheet like (Tag number, calibration range, process parameters etc.) in the factory prior to despatch. Vendor shall submit the transmitter configuration report prior to inspection.	
20	--	Painting shall be as per manufactured standard suitable for the given application.	
21	--	<u>Mandatory Spares :</u> A) 10% or minimum one number for each type of transmitter/receiver/sensor, B) 10 % or minimum one number of electronic card of each type. (The word 'TYPE' means the Make, Model no.,Type, Range,Size/Length, Rating, Material as applicable.).	
22	--	<u>Commissioning spares:</u> Vendor to recommend and include commissioning spares in base price.	
23	--	<u>Spares for 2 years Operation and maintenance:</u> Vendor shall include list of spares for 2-years operation and maintenance as per vendor recommendation along with the offer. The prices for 2-year operation and maintenance spares shall be valid for at least 2 years from date of main order	
24	--	<u>Site assistance and supervision:</u> Vendor to consider 2 days of site assistance and supervision for installation / Pre-Commissioning / Commissioning for each ultrasonic flow meter in the offer. Special tools shall be arranged by supplier for the duration of site visit.	

Plant PPU & CDW	Client IOCL, PANIPAT REFINERY	Contract Code RHQ, EPCM-3 (P-25)	Document ID 6746-INS-022-EC-0130	Contract No. 66-6746
	TECHNICAL SPECIFICATIONS – ULTRASONIC FLOWMETERS INLINE (INSERTION) TYPE			
				Rev 00 Page 12 of 19

		<p>Also, Vendor to provide per diem rates for Supervision of installation / Pre-Commissioning / Commissioning of Ultrasonic flowmeter. Special tools shall be arranged by supplier for the duration of site visit. The per diem rates shall include lodging, boarding, local transport, medical, all insurance including third party, withholding tax, Income Tax, Corporate Tax (as may be applicable) etc. & all other incidental charges. For detailed Terms & Conditions, please refer Instructions to Bidder document which is part of Commercial Documents attached elsewhere.</p>	
--	--	--	--

Plant PPU & CDW	Client IOCL, PANIPAT REFINERY	Contract Code RHQ, EPCM-3 (P-25)	Document ID 6746-INS-022-EC-0130	Contract No. 66-6746	
	TECHNICAL SPECIFICATIONS – ULTRASONIC FLOWMETERS INLINE (INSERTION) TYPE				
	Rev	00	Page		13

INSPECTION AND TESTING



The vendor shall be fully responsible for completing all the in-house testing and test reports as indicated below.

The same shall be submitted to IIIrd party minimum 7 days before inspection. Any delay due to late submission will not be considered as reason for delay in delivery.

Refer attachment “Technical Requirements for pipe, Fitting, Flanges, Gaskets & fasteners” Document no:-6746-PIP-00-EC-0005 Rev-0.

Following tests shall be offered as a minimum. Percentages indicated are for each lot offered for inspection. These are indicative only and the number of instruments selected as well as the inspection procedure followed, shall be at the sole discretion of inspection engineer of III party. The inspecting authority may, if desired, request for additional tests over and above those listed below, or decide to waive the inspection, partly or fully.

SR. NO.	DESCRIPTION	INSPECTION QUANTITY			REMARKS
		VENDOR	CLIENTS / tkIS-India	IIIRD PARTY	
1.	Visual inspection for quantity, model no., tag no., general conformity with specifications	100%		100% (W)	
2.	Hydrostatic test on metering tube as per applicable standard	100%		10%(W)	Refer Note 1
3.	Calibration at five equispaced points over entire range besides zero and span.	100%		10%(W)	Refer Note 1
4.	Permissible load resistance test.	As per vendor std.		10%(W)	Refer Note 1
5.	Power supply variation test for satisfactory operation	As per vendor std.		10%(W)	Refer Note 1
6.	Bi-directional communication test with hand held configurator and checking the configuration.	As per vendor std.		10%(W)	
7.	Tests for correct cable entries on metering tube and transmitter.	As per vendor std.		100% (W)	
8.	Functional checks for flow meter including transmitter and output indicator. This shall also include verification of necessary parameter like, tag no., ranges etc. on transmitter.	100%		10%(W)	
9.	Positive material identification test	100%		10% (W)	For all SS wetted Parts

Plant PPU & CDW	Client IOCL, PANIPAT REFINERY	Contract Code RHQ, EPCM-3 (P-25)	Document ID 6746-INS-022-EC-0130	Contract No. 66-6746
	TECHNICAL SPECIFICATIONS – ULTRASONIC FLOWMETERS INLINE (INSERTION) TYPE			
	Rev 00	Page 14	of 19	



					As per document: PMI 6-81-0001 rev 0 Note-1
10.	Inter Granular Corosion (IGC) Test	100%		Review	Review of test reports for all SS wetted parts Refer document:- 6746-PIP-000-EC-0005
11.	Radiography for casting and welds, PWHT	100%		Document Review	
12.	Dye Penetrant Testing for all welded, machined or heat affected zones	100%		Document Review	
13.	Painting and Packing Visual check, Suitable protection for meters to prevent entry of foreign material	100%		100% (W)	

Inspection and Testing for H2 Service (applicable if indicated in datasheet)

Apart from the above Inspections and testing requirements in above table, additional requirements of inspection and testing for H2 service are as follows:

SR. NO.	DESCRIPTION	INSPECTION QUANTITY			REMARKS
		VENDOR	CLIENTS / tkIS - INDIA	IIIRD PARTY	
1.	Radiography for casting and weld joints	100%		100% Document review	
2.	Dye Penetrant testing	100%		100% Document review	
a.	Ferrite No. check for welds 3< FN <10	100%		10% (W)	Note-1
3.	Hardness Test	100%		10% (W)	Note-1
4.	Radiography for casting and weld joints	100%		100% Document review	

In addition to above, Refer attached technical requirements for H2 service document (RHQ-EC-ML-0001 2021 page 36 to 38 of 94 for requirements applicable for Hydrogen service. Vendor shall include required testing as indicated in the attached document in addition to testing requirements indicated below.

Plant PPU & CDW	Client IOCL, PANIPAT REFINERY	Contract Code RHQ, EPCM-3 (P-25)	Document ID 6746-INS-022-EC-0130	Contract No. 66-6746	
	TECHNICAL SPECIFICATIONS – ULTRASONIC FLOWMETERS INLINE (INSERTION) TYPE				
				Rev	00

Note 1 : In case of fully imported meters, vendor shall provide relevant internal test reports, confirmatory certificates from the original manufacturing facility shall be submitted for review by tkIS-India. Any problem arising due to exemption of the above mentioned tests shall be promptly attended and rectified free of cost by the vendor.

NOTE 2: Material test certificates, NDT reports, internal test reports, CCoE/IS/Ex'd' certificates shall be made available for inspection and to be submitted to TPIA/tkIS/OWNER for review.

Abbreviations :



W : Witness

R : Review

Test and Calibration Instruments

Vendor shall arrange for all the test and calibration instruments and provide all the facilities/assistance for inspection and testing. Accuracy of test and measuring instruments used by the vendor shall be at least two times better than the accuracy of the instrument being tested. All the test and measuring instruments shall be calibrated in a standard laboratory and the vendor shall produce valid calibration documents for the purposes of verification. The calibration shall be traceable to any of the approved national laboratories.

Hand held configurator (HART or Foundation Fieldbus as applicable) required for testing communication and configuration.

Plant PPU & CDW	Client IOCL, PANIPAT REFINERY	Contract Code RHQ, EPCM-3 (P-25)	Document ID 6746-INS-022-EC-0130	Contract No. 66-6746	
	TECHNICAL SPECIFICATIONS – ULTRASONIC FLOWMETERS INLINE (INSERTION) TYPE				
	Rev	00	Page		16

DOCUMENTATION REQUIREMENTS



SR. NO.	DOCUMENT	FOR INFORMATION AFTER PO/LOI				FOR APPROVAL AFTER PO/LOI				FINAL COPIES	
		TIME SCH. WEEK	COPIES (NOTE A)			TIME SCH. WEEK	COPIES (NOTE B)			S (1)	P (1)
			CLIENTS	tkIS-India			CLIENTS	tkIS-India			
1.	Installation, operation and maintenance manual	---	---	---	---	---	---	---	---	2	6
2.	Parts list	---	---	---	---	---	---	---	---	2	6
3.	Dimensional drawings	2	1S+1P	1S+1P	---	---	---	---	---	2	6
4.	Sizing calculations	---	---	---	---	2	1S	1S	---	2	6
5.	Internal test reports	Minimum 7 days before Inspection	1S+1P	1S+1P	---	---	---	---	---	2	6
6.	Flameproof certification wherever applicable	Minimum 7 days before Inspection	1S+1P	1S+1P	---	---	---	---	---	2	6
7.	CCOE approval wherever applicable	Minimum 7 days before Inspection	1S+1P	1S+1P	---	---	---	---	---	2	6
8.	Configuration sheets of instruments	---	---	---	---	---	---	---	---	2	6
9.	Third party inspection reports	Post third party inspection	1S	1S	---	---	---	---	---	2	6

1. Abbreviations:



S : Soft copies (.pdf files)

P : Prints

2. Notes:

Plant PPU & CDW	Client IOCL, PANIPAT REFINERY	Contract Code RHQ, EPCM-3 (P-25)	Document ID 6746-INS-022-EC-0130	Contract No. 66-6746	
	TECHNICAL SPECIFICATIONS – ULTRASONIC FLOWMETERS INLINE (INSERTION) TYPE				
	Rev	00	Page		17

- a) For Vendor documentation, wherever review/approval is specified, soft copy shall be sent to tkisindia.ioclp25.epcm3@thyssenkrupp.com with copy to m.joshi@thyssenkrupp.com .
Once the document is reviewed / approved, final sets of documents shall be sent to tkIS DMS office for further compilation as per following address. These shall not be dispatched to site directly.
- thyssenkrupp Industrial Solutions (India) Private Limited
Kind Attn.:- Mr. Mandar U Joshi, Project Manager (PM)
6th floor, Tower “C”, Panchshil Business Park, Baner-Balewadi Road,
Pune 411 045, India
Tel. : 020 4621 1222
Fax : 020 4621 1300
TF Email ID : tkisindia.ioclp25.epcm3@thyssenkrupp.com
Email : m.joshi@thyssenkrupp.com
- b) Drawings to be submitted for approval shall be submitted as per timeline indicated above and in line with order specifications. Any deviations with respect to order specifications shall be listed separately. In absence of same, order specification will be governing document. It is vendor responsibility to get drawings approved and if required vendor to visit tkIS office to get drawings approved. Delivery period shall be as per terms and conditions of Purchase order and any delay in drawing approval will not be considered as reason for delay in delivery.
- c) Drawings submitted for information shall not be approved by tkIS - India. Vendor to note that documents prepared for the purpose of manufacturing shall not be sent to tkIS - India for approval. tkIS - India shall not be responsible for any mistakes/omissions in these documents as well as any delays due to the same. Specifications of instruments ordered shall be strictly as per tkIS - India data sheets which shall also form the basis for inspection.
- d) Refer Vendor Documentation Procedure 6746-PMG-000-BD-0002 & Vendor Coordination Procedure 6746-PMG-000-BD-0004 attached to the MR.

Plant PPU & CDW	Client IOCL, PANIPAT REFINERY	Contract Code RHQ, EPCM-3 (P-25)	Document ID 6746-INS-022-EC-0130	Contract No. 66-6746
	TECHNICAL SPECIFICATIONS – ULTRASONIC FLOWMETERS INLINE (INSERTION) TYPE			
	Rev	00	Page	

COMPLIANCE DECLARATION & PTR

Please note that vendor shall indicate his replies to the following points without which the offer shall be liable for rejection.

Deviations, if any, from tkIS-India specifications, shall be listed in the enclosed format (List of Deviations) indicating the applicable specification clause. The vendor will be made liable for full compliance with the specification requirements, if deviations are not listed in 'List of Deviations', as it will be deemed as 'No deviation'.

SR. NO.	DESCRIPTION	EXPECTED REPLY	CONFIRMATION BY VENDOR	REMARKS
1.	Confirm that all deviations against tkIS-India specifications are consolidated under "List of Deviations". Deviations mentioned elsewhere will not be taken into consideration.	No Deviation		
2.	Confirm that a soft copy of the technical bid, as per the attached format, is submitted with the technical offer.	Yes		
3.	Confirm that there is no discrepancy in the technical details outlined in the hard and soft copy of the offer.	No Discrepancy		
4.	Relevant Catalogues / literature giving specifications for all models offered including sizing data is enclosed with the offer.	Yes		
5.	Relevant Catalogues/specifications of all bought out items is enclosed with the offer.	Yes		
6.	Quoted for Spare parts recommended for 2 years continuous trouble-free operation along with listing.	Quoted		
7.	Quoted and offered recommended Commissioning spares along with listing.	Quoted		
8.	Quoted for 'Mandatory spares' if specified in tkIS-India specifications along with listing.	Quoted		



(Signature of Vendor)

Name:

Designation :

Date :

(Company Seal)

Plant PPU & CDW	Client IOCL, PANIPAT REFINERY	Contract Code RHQ, EPCM-3 (P-25)	Document ID 6746-INS-022-EC-0130	Contract No. 66-6746	
	TECHNICAL SPECIFICATIONS – ULTRASONIC FLOWMETERS INLINE (INSERTION) TYPE				
					Rev

LIST OF DEVIATIONS

Sr. No.	Doc. No:		Subject / Description	Deviation
	Clause No.	Page No.		

(Signature of Vendor)

Name:

Designation :

Date :

(Company Seal)

Sr No	Tag Number	Instrument Type	Remark
1	22-FT-35301	Ultrasonic Flowmeter	Inline (insertion) type - Flanged with spool piece

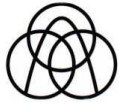

thyssenkrupp
Industrial Solutions

Piping Specification

Piping Class: A4A

IOCL EPCM-3

Projectnumber : 66-6746
 Part : 4
 Page : 73
 Print Date : 17.01.2023
 Print Time : 15:51

Basic Material: A 333 Gr.6/A671 GR CC60 CL32 Facing: RF, Corrosion allowance: 1.5 MM

Rating: Class 150	Temperature Deg C:	-45	38	93	149	204										
	Pressure Kg/Cm2(g):	18,63	18,63	17,92	16,17	14,06										

Piping Schedule

B36.10M	DN	1/2"	3/4"	1"	1 1/2"	2"	3"	4"	6"	8"	10"	12"	14"	16"	18"
	OD	21,3	26,7	33,4	48,3	60,3	88,9	114,3	168,3	219,1	273,0	323,8	355,6	406,4	457,0
	Thk	4,78	5,56	4,55	5,08	5,54	5,49	6,02	7,11	8,18	9,27	9,53	9,53	9,53	9,53
	Sch	160	160	XS	XS	XS	STD	STD	STD	STD	STD	STD	STD	STD	STD
CONTINUE	DN	20"	24"	26"	28"										
	OD	508,0	610,0	660,0	711,0										
	Thk	9,53	9,53	9,53	9,53										
	Sch	STD	STD	STD	STD										

Pipe	Designation	Rating Class	DN		Material	Standard	End Connection	Note
			from	to				
P	PB 290R	PIPE,SMLS,LTCS	1/2"	3/4"	A333 Gr.6	B36.10M	PE,SCH 160	
P	PB 290M	PIPE,SMLS,LTCS	1"	1 1/2"	A333 Gr.6	B36.10M	PE,SCH XS	
P	P 290M	PIPE,SMLS,LTCS	2"	2"	A333 Gr.6	B36.10M	BW ENDS,SCH XS	
P	P 290H	PIPE,SMLS,LTCS	3"	14"	A333 Gr.6	B36.10M	BW ENDS,SCH STD	
P	P W290H	PIPE,EFW,LTCS	16"	28"	A671 GR CC60 CL32	B36.10M	BW ENDS,SCH STD	

Fittings

E	LE 292	ELB,90 DEG,LTCS	6000	1/2"	3/4"	A350 Gr.LF2 CL.1	B16.11	SW ENDS	
E	LE 291	ELB,90 DEG,LTCS	3000	1"	1 1/2"	A350 Gr.LF2 CL.1	B16.11	SW ENDS	
E	E 290M	ELB,90 DEG,LR,LTCS		2"	2"	A420 Gr.WPL6-S	B16.9	BW ENDS,SCH XS	
E	E 290H	ELB,90 DEG,LR,LTCS		3"	14"	A420 Gr.WPL6-S	B16.9	BW ENDS,SCH STD	
E	E W290H	ELB,90 DEG,LR,LTCS		16"	28"	A420 Gr.WPL6-W	B16.9	BW ENDS,SCH STD	
EB	EB 290R	PIPE BEND,90 DEG,LR,LTCS,R=5xD		1/2"	3/4"	A333 GR.6	B16.9	BW ENDS, SCH 160	
EB	EB 290M	PIPE BEND,90 DEG,LR,LTCS,R=5xD		1"	1"	A333 GR.6	B16.9	BW ENDS, SCH XS	
EF	LF 292	ELB,45 DEG,LTCS	6000	1/2"	3/4"	A350 Gr.LF2 CL.1	B16.11	SW ENDS	
EF	LF 291	ELB,45 DEG,LTCS	3000	1"	1 1/2"	A350 Gr.LF2 CL.1	B16.11	SW ENDS	
EF	EF 290M	ELB,45 DEG,LR,LTCS		2"	2"	A420 Gr.WPL6-S	B16.9	BW ENDS,SCH XS	

1	12-08-22								
Revision	Date	Name	Checked	Description	Revision	Date	Name	Checked	Description

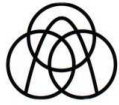

thyssenkrupp
Industrial Solutions

Piping Specification

Piping Class: A4A

IOCL EPCM-3

Projectnumber : 66-6746
Part : 4
Page : 74

Print Date : 17.01.2023
Print Time : 15:51

Fittings	Designation	Rating Class	DN		Material	Standard	End Connection	Note
			from	to				
EF	EF 290H		3"	14"	A420 Gr.WPL6-S	B16.9	BW ENDS,SCH STD	
EF	EFW290H		16"	28"	A420 Gr.WPL6-W	B16.9	BW ENDS,SCH STD	
R	LO 292	6000	3/4"	3/4"	A350 Gr.LF2 CL.1	B16.11	SW ENDS	
R	LO 291	3000	1"	1 1/2"	A350 Gr.LF2 CL.1	B16.11	SW ENDS	
R	EO 290M		2"	2"	A420 Gr.WPL6-S	B16.9	BW ENDS,SCH XS	
R	EO 290H		3"	14"	A420 Gr.WPL6-S	B16.9	BW ENDS,SCH STD	
R	EOW290H		16"	28"	A420 Gr.WPL6-W	B16.9	BW ENDS, SCH STD	
RE	EX 290M		2"	2"	A420 Gr.WPL6-S	B16.9	BW ENDS,SCH XS	
RE	EX 290H		3"	14"	A420 Gr.WPL6-S	B16.9	BW ENDS,SCH STD	
RE	EXW290H		16"	28"	A420 Gr.WPL6-W	B16.9	BW ENDS,SCH STD	
RXA	EL 292	6000	1"	14"	A350 LF2 CL1	MFG STD	SW ENDS	
RXA	ELTW292H		16"	16"	A420 GR.WPL6-W	MFG STD	BW ENDS,SCH STD	
RXB	EL 293	3000	1 1/2"	14"	A350 LF2 CL1	MFG STD	SW ENDS	
RXC	EL 292H		4"	14"	A420 GR.WPL6-S	MFG STD	BW ENDS,SCH STD	
RXD	EL 292H		28"	28"	A420 GR.WPL6-S	MFG STD	BW ENDS,SCH STD	
T	LT 292	6000	1/2"	1 1/2"	A350 Gr.LF2 CL.1	B16.11	SW ENDS	1
T	LT 291	3000	1"	1 1/2"	A350 Gr.LF2 CL.1	B16.11	SW ENDS	1
T	ET 290M		2"	2"	A420 Gr.WPL6	B16.9	BW ENDS,SCH XS	1
T	EG 060		2"	28"	SAME AS PIPE			
T	ET 290H		3"	14"	A420 Gr.WPL6	B16.9	BW ENDS,SCH STD	1
T	EG 060A		3"	28"	SAME AS PIPE			
T	ETW290H		16"	28"	A420 Gr.WPL6-W	B16.9	BW ENDS,SCH STD	1
C	LK 292	6000	1/2"	3/4"	A350 Gr.LF2 CL.1	B16.11	SW ENDS	
C	LK 291	3000	1"	1 1/2"	A350 Gr.LF2 CL.1	B16.11	SW ENDS	
C	EK 290M		2"	2"	A420 Gr.WPL6-S	B16.9	BW ENDS,SCH XS	
C	EK 290H		3"	28"	A420 Gr.WPL6-S	B16.9	BW ENDS,SCH STD	
CA	UK 291	3000	1/2"	1 1/2"	A350 Gr.LF2 CL.1	B16.11	THREADED END, FNPT	26
M	LM 292	6000	1/2"	3/4"	A350 Gr.LF2 CL.1	B16.11	SW ENDS	
M	LM 291	3000	1"	1 1/2"	A350 Gr.LF2 CL.1	B16.11	SW ENDS	
MI	UM 291	3000	1/2"	1/2"	A350 GR.LF2,CL1	B16.11	SCRD ENDS,NPT(F)	
N	PN 290SA		1/2"	3/4"	A333 Gr.6	B36.10M	PE X TOE(M) TO B1.20.1,SCH XXS	
N	PN 290RA		1"	1 1/2"	A333 Gr.6	B36.10M	PE X TOE(M) TO B1.20.1,SCH 160	

Revision	Date	Name	Checked	Description	Revision	Date	Name	Checked	Description
1	12-08-22								



thyssenkrupp
Industrial Solutions

Piping Specification

Piping Class: A4A

IOCL EPCM-3

Projectnumber : 66-6746
Part : 4
Page : 75

Print Date : 17.01.2023
Print Time : 15:51

Fittings	Designation	Rating Class	DN		Material	Standard	End Connection	Note
			from	to				
NA	PN 290R		1/2"	3/4"	A333 Gr.6	B36.10M	PBE,SCH 160	
NA	PN 290M		1"	1 1/2"	A333 Gr.6	B36.10M	PBE,SCH XS	
RA	EWO290R		3/4"	3/4"	A350 GR.LF2 CL.1	BS-3799	PBE,SCH 160	
RA	EWO290M		1"	1 1/2"	A350 GR.LF2 CL.1	BS-3799	PBE,SCH XS	
RA	EWO290AM		2"	2"	A350 GR.LF2 CL.1	BS-3799	SMALL PE & LARGE BW END,SCH XS	
RA	EWO290AH		3"	3"	A350 GR.LF2 CL.1	BS-3799	SMALL PE& LARGE BW END,SCH STD	
RB	EWX290R		3/4"	3/4"	A350 GR.LF2 CL.1	BS-3799	PBE, SCH 160	
RB	EWX290M		1"	1 1/2"	A350 GR.LF2 CL.1	BS-3799	PBE, SCH XS	
RB	EWX290AM		2"	2"	A350 GR.LF2 CL.1	BS-3799	SMALL PE & LARGE BW END,SCH XS	
RB	EWX290AH		3"	3"	A350 GR.LF2 CL.1	BS-3799	SMALL PE& LARGE BW END,SCH STD	
T	LV 292	6000	2"	28"	A350,LF2,CL1	B16.11	SW ENDS	1
T	LV 291	3000	3"	28"	A350,LF2,CL1	B16.11	SW ENDS	1

Flanges								
F	Designation	Rating Class	DN	DN	Material	Standard	End Connection	Note
			from	to				
F	F D290R	150	1/2"	3/4"	A350 Gr.LF2 CL.1	B16.5	BW END, SCH 160,RF	
F	F D290M	150	1"	2"	A350 Gr.LF2 CL.1	B16.5	BW END, SCH XS,RF	
F	F D290H	150	3"	24"	A350 Gr.LF2 CL.1	B16.5	BW END, SCH STD,RF	
F	F D290HB	150	26"	28"	A350 Gr.LF2 CL.1	B16.47,SR.B	BW END, SCH STD,RF	
FA	FWD291R	300	1/2"	3/4"	A350 Gr.LF2 CL.1	B16.5	SW END, SCH 160,RF	40
FA	FWD291M	300	1"	1 1/2"	A350 Gr.LF2 CL.1	B16.5	SW END, SCH XS,RF	40
FA	F D291M	300	2"	2"	A350 Gr.LF2 CL.1	B16.5	BW END, SCH XS,RF	40
FA	F D291H	300	3"	24"	A350 Gr.LF2 CL.1	B16.5	BW END, SCH STD,RF	40
FAB	FWD292R	600	1/2"	3/4"	A350 Gr.LF2 CL.1	B16.5	SW END, SCH 160,RF	2
FAB	FWD292M	600	1"	1 1/2"	A350 Gr.LF2 CL.1	B16.5	SW END, SCH XS,RF	2
FAB	F D292M	600	2"	2"	A350 Gr.LF2 CL.1	B16.5	BW END, SCH XS,RF	2
FAD	F D294R	1500	1/2"	3/4"	A350 Gr.LF2 CL.1	B16.5	BW END, SCH 160,RF	
FAD	F D294M	1500	1"	2"	A350 Gr.LF2 CL.1	B16.5	BW END, SCH XS,RF	
FAG	F W295M	2500	1"	1"	A350 GR.LF2 CL.1	B16.5, RTJ	BW ENDS, SCH XS	
FB	FBD290	150	1/2"	24"	A350 Gr.LF2 CL.1	B16.5	RF	
FB	FBD290B	150	26"	28"	A350 Gr.LF2 CL.1	B16.47,SR.B	RF	

Bolts								
Revision	Date	Name	Checked	Description	Revision	Date	Name	Description
1	12-08-22							

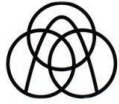

thyssenkrupp
Industrial Solutions

Piping Specification

Piping Class: A4A

IOCL EPCM-3

Projectnumber : 66-6746
Part : 4
Page : 76

Print Date : 17.01.2023
Print Time : 15:51

Bolts	Designation	Rating Class	DN		Material	Standard	End Connection	Note
			from	to				
B	B 291	SBOLT	1/2"	28"	A320 Gr.L7/A194 Gr.7	B18.2.1/B18.2.2		
BBA	B 291	SBOLT	1/2"	28"	A320 Gr.L7/A194 Gr.7	B18.2.1/B18.2.2		22
BBB	B 291	SBOLT	1"	2"	A320 Gr.L7/A194 Gr.7	B18.2.1/B18.2.2		41

Gaskets								
			Rating Class	DN from	DN to	Material	Standard	Note
G	DU 451	SP WD GASKET	150	1/2"	24"	SS 316/FLX GRPH	B16.20/B16.5	1#
G	DU 451B	SP WD GASKET	150	26"	28"	SS 316/FLX GRPH	B16.20/B16.47,B	
GA	DU 452	SP WD GASKET	300	1/2"	24"	SS 316/FLX GRPH	B16.20/B16.5	41
GAA	DU 453	SP WD GASKET	600	1"	2"	SS 316/FLX GRPH	B16.20/B16.5	41

Others								
			Rating Class	DN from	DN to	Material	Standard	Note
WB	WBC290	SBLD, LTCS	150	1/2"	8"	A350 GR.LF2 CL.1	B16.48,FF	FOR RF FLG,B16.5
WB	WUC290	SPACER & BLIND, LTCS	150	10"	24"	A350 GR.LF2 CL.1	B16.48,FF	FOR RF FLG,B16.5
WB3	WBC292	SBLD, LTCS	600	1/2"	4"	A350 GR.LF2 CL.1	B16.48,FF	FOR RF FLG,B16.5
WA	WAX291	ADAPTOR,LTCS		1/2"	1 1/2"	A350 GR.LF2 CL.1	PINLES-PIP-6265	FOR SW ENDS VALVES,B16.11
WAA	WAC291	ADAPTOR,FLGD, LTCS	300	1/2"	2"	A 350 LF2 CL 1	PINLES-PIP-6265	FLGD,B16.5, RF
WS	WS 291	HOSE COUPLER,LTCS	3000	1/2"	1 1/2"	A350 GR.LF2,CL1	MFG STD	ONE END QRC X OTHER END SW

Valves	Designation	Rating Class	DN		Body	Material		Packing	Standard	End Connection	Note
			from	to		Body Seat					
V	V X294	GLOBE VALVE,LTCS	800	1/2"	1 1/2"	A350 Gr.LF2 CL.1	SS 304+STELLITED	FLEXIBLE GRAPHITE	BS EN ISO 15761	SW ENDS, B16.11	
V	V D290	GLOBE VALVE,LTCS	150	2"	10"	A352 GR.LCB	SS 304+STELLITED	FLEXIBLE GRAPHITE	BS 1873	FLGD,B16.5,RF	
V	V D290G	GLOBE VALVE,LTCS,GO	150	12"	16"	A352 GR.LCB	SS 304+STELLITED	FLEXIBLE GRAPHITE	BS 1873	FLGD,B16.5,RF	3
VA	VXC290G	BUTTERFLY VALVE, GO,LTCS	150	6"	24"	A352 GR LCB	SS304+STELLITED	FLEX+GRPH+BRD+RING	BS EN 593	FOR RF FLGS,B16.5	3
VG	SIX294	GATE VALVE, LTCS	800	1/2"	1 1/2"	A350 Gr.LF2 CL.1	SS 304+STELLITED	FLEXIBLE GRAPHITE	API 602	SW ENDS,B16.11	
VG	SKD290	GATE VALVE,LTCS	150	2"	10"	A352 Gr.LCB	SS 304+STELLITED	FLEXIBLE GRAPHITE	API 600	FLGD, B16.5, RF	
VG	SKD290G	GATE VALVE,LTCS,GO	150	12"	24"	A352 Gr.LCB	SS 304+STELLITED	FLEXIBLE GRAPHITE	API 600	FLGD, B16.5, RF	3
VGL	SKD290L	GATE VAL,LTCS,LOCKING FACILITY	150	2"	10"	A352 Gr.LCB	SS 304+STELLITED	FLEXIBLE GRAPHITE	API 600	FLGD, B16.5, RF	19
VGL	SKD290GL	GATE VALVE,LTCS,GO,WITH LOCK	150	12"	24"	A352 Gr.LCB	SS 304+STELLITED	FLEXIBLE GRAPHITE	API 600	FLGD, B16.5, RF	18
VK	VKC290	BALL VALVE,LO,LTCS,FB,EXT.STEM	150	1/2"	4"	A350 LF2/A352 GR LCB	RPTFE	GRAFOIL	ISO 17292	FLGD B16.5,RF	
VK	VKC290G	BALL VALVE,GO,LTCS,FB	150	6"	18"	A352 GR LCB	RPTFE	GRAFOIL	ISO 17292	FLGD B16.5,RF	3
VKA	VKC291	BALL VALVE,LO,LTCS,FB	300	1/2"	4"	A350 LF2/A352 GR LCB	RPTFE	GRAFOIL	ISO 17292	FLGD B16.5,RF	22

1	12-08-22									
Revision	Date	Name	Checked	Description	Revision	Date	Name	Checked	Description	

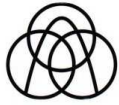

thyssenkrupp
Industrial Solutions

Piping Specification

Piping Class: A4A

IOCL EPCM-3

Projectnumber : 66-6746
Part : 4
Page : 77

Print Date : 17.01.2023
Print Time : 15:51

Valves	Designation	Rating Class	DN		Body	M a t e r i a l		Packing	Standard	End Connection	Note
			from	to		Body Seat					
VKB	VKC291M	300	1/2"	4"	A350 LF2/A352 GR LCB	SS304		GRAFOIL	ISO 17292	FLGD B16.5,RF	22
VKL	VKC290L	150	1/2"	4"	A350 LF2/A352 GR LCB	RPTFE		GRAFOIL	ISO 17292	FLGD B16.5,RF	19
VKL	VKC290GL	150	6"	18"	A352 GR LCB	RPTFE		GRAFOIL	ISO 17292	FLGD B16.5,RF	19
VN	V N294	800	1/2"	1 1/2"	A350 Gr.LF2 CL.1	SS 304+STELLITED		FLEXIBLE GRAPHITE	API 602	SW ENDS, B16.11	
VC	R X294	800	1/2"	1 1/2"	A350 Gr.LF2 CL.1	SS 304+STELLITED			API 602	SW ENDS, B16.11	
VC	RKD290	150	2"	24"	A352 GR,LCB	SS 304+STELLITED			BS 1868	FLGD,B16.5, RF	

Notes

1# - I RING MATERIAL SAME AS SPIRAL
18 - WITH LOCKING + GEAR OPERATION.
19 - WITH LOCKING ARRANGEMENT.
1 - FOR TYPE OF BRANCH REFER PART3

22 - FOR CLASS 300
26 - FOR INSTRUMENTATION USE ONLY
2 - FOR CLASS 600
3 - GEAR OPERATED VALVES

40 - FOR CL. 300 FLANGES
41 - FOR CL. 600 FLANGES
9 - FOR PI AND PG CONNECTIONS

Revision	Date	Name	Checked	Description	Revision	Date	Name	Checked	Description
1	12-08-22								

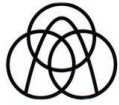

thyssenkrupp
Industrial Solutions

Piping Specification

Piping Class: A1K

IOCL EPCM-3

Projectnumber : 66-6746
 Part : 4
 Page : 16
 Print Date : 17.01.2023
 Print Time : 15:51

Basic Material: A312 Gr.TP304/A358 Gr.304 CL.1 Facing: RF Corrosion allowance: 0.0 MM

Rating: Class 150	Temperature Deg C:	38	93	149	204	260	316	343	371				
	Pressure Kg/Cm2(g):	19,33	16,17	14,41	13,36	11,95	9,84	8,79	7,73				

Piping Schedule

B36.19M	DN	1/2"	3/4"	1"	1 1/2"	2"	3"	4"	6"	8"				
	OD	21,3	26,7	33,4	48,3	60,3	88,9	114,3	168,3	219,1				
	Thk	3,73	3,91	3,38	3,68	3,91	3,05	3,05	3,40	3,76				
	Sch	80S	80S	40S	40S	40S	10S	10S	10S	10S				
B36.19M	DN	10"	12"	14"	16"	18"	20"	22"	24"					
	OD	273,0	323,8	355,6	406,4	457,0	508,0	559,0	610,0					
	Thk	4,19	4,57	4,78	4,78	4,78	5,54	5,54	6,35					
	Sch	10S	10S	10S	10S	10S	10S	10S	10S					

Pipe	Designation	Rating Class	DN		Material	Standard	End Connection	Note
			from	to				
P	PB 360L	PIPE,SMLS,SS	1/2"	3/4"	A312 TP 304	B36.19M	PE, SCH 80S	
P	PB 360J	PIPE,SMLS,SS	1"	1 1/2"	A312 TP 304	B36.19M	PE, SCH 40S	
P	P 360J	PIPE,SMLS,SS	2"	2"	A312 TP 304	B36.19M	BW ENDS, SCH 40S	
P	P 360C	PIPE,SMLS,SS	3"	8"	A312 TP 304	B36.19M	BW ENDS, SCH 10S	
P	P W364C	PIPE,EFW,SS	10"	24"	A358 Gr.304 CL.1	B36.19M	BW ENDS,SCH 10S	

Fittings

E	LE 361	ELB,90 DEG, SS	3000	1/2"	1 1/2"	A182 GR.F304	B16.11	SW ENDS	
E	E 360J	ELB,90 DEG,LR, SS		2"	2"	A403 WP304-S	B16.9	BW ENDS, SCH 40S	
E	E 360C	ELB,90 DEG,LR, SS		3"	8"	A403 WP304-S	B16.9	BW ENDS, SCH 10S	
E	E W361C	ELB,90 DEG,LR,SS		10"	24"	A403 Gr.WP304-WX	B16.9	BW ENDS,SCH 10S	
EB	EB 361L	PIPE BEND,90 DEG,LR,SS,R=5xD		1/2"	3/4"	A312 TP304-S	B16.9	BW ENDS,SCH 80S	
EB	EB 361J	PIPE BEND,90 DEG,LR,SS,R=5xD		1"	1 1/2"	A312 TP304-S	B16.9	BW ENDS, SCH 40S	
EF	LF 361	ELB,45 DEG, SS	3000	1/2"	1 1/2"	A182 GR. F304	B16.11	SW ENDS	
EF	EF 360J	ELB,45 DEG,LR, SS		2"	2"	A403 WP304-S	B16.9	BW ENDS, SCH 40S	
EF	EF 360C	ELB,45 DEG,LR, SS		3"	8"	A403 WP304-S	B16.9	BW ENDS, SCH 10S	
EF	EFW361C	ELB,45 DEG,LR,SS		10"	24"	A403 Gr.WP304-WX	B16.9	BW ENDS,SCH 10S	

1	12-08-22								
Revision	Date	Name	Checked	Description	Revision	Date	Name	Checked	Description

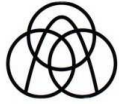

thyssenkrupp
Industrial Solutions

Piping Specification

Piping Class: A1K

IOCL EPCM-3

Projectnumber : 66-6746
Part : 4
Page : 17

Print Date : 17.01.2023
Print Time : 15:51

Fittings	Designation	Rating Class	DN		Material	Standard	End Connection	Note	
			from	to					
R	LO 361	RCPL, SS	3000	3/4"	1 1/2"	A182 GR.F304	MSS-SP95/MF STD	SW ENDS TO B16.11	
R	EO 360J	CON RED, SS		2"	2"	A403 WP304-S	B16.9	BW ENDS, SCH 40S	
R	EO 360C	CON RED, SS		3"	8"	A403 WP304-S	B16.9	BW ENDS, SCH 10S	
R	EOW361C	CON RED,SS		10"	24"	A403 Gr.WP304-WX	B16.9	BW ENDS,SCH 10S	
RE	EX 360J	ECC RED, SS		2"	2"	A403 WP304-S	B16.9	BW ENDS, SCH 40S	
RE	EX 360C	ECC RED, SS		3"	8"	A403 WP304-S	B16.9	BW ENDS, SCH 10S	
RE	EXW361C	ECC RED,SS		10"	24"	A403 Gr.WP304-WX	B16.9	BW ENDS,SCH 10S	
T	LT 361	TEE, SS	3000	1/2"	1 1/2"	A182 GR.F304	B16.11	SW ENDS	1
T	ET 360J	TEE, SS		2"	2"	A403 WP304-S	B16.9	BW ENDS, SCH 40S	1
T	EG 360A	STUB IN WITH PAD		2"	24"	SAME AS PIPE			1
T	ET 360C	TEE, SS		3"	8"	A403 WP304-S	B16.9	BW ENDS, SCH 10S	1
T	EG 360	STUB IN,SS		3"	24"	SAME AS PIPE			1
T	ETW361C	TEE,SS		10"	24"	A403 Gr.WP304-WX	B16.9	BW ENDS,SCH 10S	1
C	LK 361	CAP, SS	3000	1/2"	1 1/2"	A182 GR.F304	B16.11	SW ENDS	
C	EK 360J	CAP, SS		2"	2"	A403 WP304-S	B16.9	BW ENDS, SCH 40S	
C	EK 360C	CAP, SS		3"	24"	A403 WP304-S	B16.9	BW ENDS, SCH 10S	
CX	UK 361	CAP, SS	3000	1/2"	1 1/2"	A182 GR.F304	B16.11	SCRD ENDS, NPT (F)	3
M	LM 361	FCPL, SS	3000	1/2"	1 1/2"	A182 GR.F304	B16.11	SW ENDS	
MI	LM 361I	FCPL,SS,THREADED ENDS,(F)NPT	3000	1/2"	1/2"	ASTM A182 F304	B16.11	THREADED ENDS,NPT(F)	90
N	PNB360L	NIPPLE, SS		1/2"	1 1/2"	A312 TP 304	B36.19M	PE x MNPT, SCH 80S	
NI	PNB360LI	NIPPLE, SS,IC HOOK UP,TOE		1/2"	3/4"	A312 TP 304	B36.19M	PE x MNPT, SCH 80S	90
NIC	PNB360LIA	NIPPLE, SS,IC HOOK UP,PBE		1/2"	3/4"	A312 TP 304	B36.19M	PBE, SCH 80S	
NII	PNB360LII	NIPPLE, SS,IC HOOK UP,PBE		1/2"	3/4"	A312 TP 304	B36.19M	PBE, SCH 80S	
RA	EWO361I	SWAGE CON, SS		3/4"	3/4"	A182 GR.F304	BS-3799	PBE,SCH 80S	90
T	LV 361	HALF COUPLING,SS	3000	2"	24"	A182 Gr.F304	B16.11	SW ENDS	1

Flanges

F	F D360L	WN FLANGE,SS	150	1/2"	3/4"	A182 Gr.F304	B16.5,RF	BW END, SCH 80S	
F	F D360J	WELDING NECK FLANGE,SS	150	1"	2"	A182 Gr.F304	B16.5,RF	BW END,SCH 40S	
F	F D360C	WELDING NECK FLANGE, SS	150	3"	24"	A182 Gr.F304	B16.5,RF	BW END, SCH 10S	
FA	FWD361L	SW FLG,SS	300	1/2"	3/4"	A182 Gr.F304	B16.5	SW END, SCH 80S,RF	22
FA	FWD361J	SW FLG,SS	300	1"	1 1/2"	A182 Gr.F304	B16.5	SW END, SCH 40S,RF	22

1	12-08-22								
Revision	Date	Name	Checked	Description	Revision	Date	Name	Checked	Description

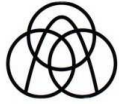

thyssenkrupp
Industrial Solutions

Piping Specification

Piping Class: A1K

IOCL EPCM-3

Projectnumber : 66-6746
Part : 4
Page : 18

Print Date : 17.01.2023
Print Time : 15:51

Flanges	Designation	Rating Class	DN		Material	Standard	End Connection	Note
			from	to				
FA	F D361J	300	2"	2"	A182 Gr.F304	B16.5	BW END, SCH 40S,RF	22
FA	F D361C	300	3"	24"	A182 Gr.F304	B16.5	BW END, SCH 10S,RF	22
FAA	FWD362L	600	1/2"	3/4"	A182 Gr.F304	B16.5	SW END, SCH 80S,RF	2
FAA	F D362J	600	1"	1"	A182 Gr.F304	B16.5	BW END, SCH 40S,RF	22
FB	FBD360	150	1/2"	24"	A182 Gr.F304	B16.5	RF	
FBB	FBD360A	150	1 1/2"	2"	A182 Gr.F304	B16.5	RF	
FBC	FBD361A	300	1 1/2"	2"	A182 Gr.F304	B16.5	RF	
FBD	FBD361	300	1/2"	16"	A182 Gr.F304	B16.5	RF	22

Bolts								
B	B 131	SBOLT WITH 2 HEAVY HEX NUTS		1/2"	24"	A193GR B7/A194GR 2H	B18.2.1/B18.2.2	
BBA	B 131	SBOLT WITH 2 HEAVY HEX NUTS		1/2"	2"	A193GR B7/A194GR 2H	B18.2.1/B18.2.2	22
BBA	B 131	SBOLT WITH 2 HEAVY HEX NUTS		22"	22"	A193GR B7/A194GR 2H	B18.2.1/B18.2.2	
BBC	B 131	SBOLT WITH 2 HEAVY HEX NUTS		1/2"	1"	A193GR B7/A194GR 2H	B18.2.1/B18.2.2	41

Gaskets								
G	DU 451	SP WD GASKET	150	1/2"	24"	SS 316/FLX GRPH	B16.20/B16.5	
GAA	DU 452	SP WD GASKET	300	1/2"	24"	SS 316/FLX GRPH	B16.20/B16.5	22
GAB	DU 453	SP WD GASKET	600	1/2"	1"	SS 316/FLX GRPH	B16.20/B16.5	41

Others								
WB	WBD362	SBLD,SS	150	1/2"	8"	A182 GR.F304	B16.48	FOR RF FLGS, B16.5
WB	WUD362	PADDLE SPCR & BLANK,SS	150	10"	24"	A182 GR.F304	B16.48	FOR RF FLGS, B16.5
WA	WAX360	ADAPTOR,SS		1/2"	1 1/2"	A182 GR.F304	PINLES-PIP-6265	FOR SW ENDS VALVES,B16.11
WAA	WAC362	ADAPTOR,FLGD, SS	300	1/2"	2"	A182 GR.F304	PINLES-PIP-6265	FLGD,B16.5, RF
WAB	WAC360	ADAPTOR,FLGD, SS	150	1/2"	2"	A182 GR.F304	PINLES-PIP-6265	FLGD,B16.5, RF
WAC	WAC363	ADAPTOR,FLGD, SS	600	1/2"	2"	A182 GR.F304	PINLES-PIP-6265	FLGD,B16.5,RF
WS	WS 360	HOSE COUPLER,SS	3000	1/2"	1 1/2"	SS 304	MFG STD	ONE END QRC X OTHER END SW

Valves	Designation	Rating Class	DN		Body	Material		Packing	Standard	End Connection	Note
			from	to		Body	Body Seat				
V	V X424	800	1/2"	1 1/2"	A182 Gr.F304	SS 304+STELLITED	FLEXIBLE GRAPHITE	BS EN ISO 15761	SW ENDS, B16.11		

1	12-08-22									
Revision	Date	Name	Checked	Description	Revision	Date	Name	Checked	Description	



thyssenkrupp
Industrial Solutions

Piping Specification

Piping Class: A1K

IOCL EPCM-3

Projectnumber : 66-6746
Part : 4
Page : 19

Print Date : 17.01.2023
Print Time : 15:51

Valves	Designation	Rating Class	DN		Body	Material		Packing	Standard	End Connection	Note
			from	to		Body Seat					
V	V D430	GLOBE VALVE,SS	150	2"	10"	A351 Gr.CF8	SS 304	FLEXIBLE GRAPHITE	BS 1873	FLGD, B16.5, RF	
V	V D430G	GLOBE VALVE,GEAR,SS	150	12"	24"	A351 Gr.CF8	SS 304	FLEXIBLE GRAPHITE	BS 1873	FLGD, B16.5, RF	6
VA	VXB430	BUTTERFLY V.,WAFER TYP,LO,SS	150	2"	4"	A351 GR.CF8	RPTFE	RPTFE	API 609	FOR RF FLANGES TO B16.5	
VA	VXB430G	BUTTERFLY V.,WAFER LUG,GEAR,SS	150	6"	24"	A351 GR.CF8	SS304	FLEX+GRPH+BRD+RING	API 609	FOR RF FLANGES TO B16.5	6
VG	SIX424	GATE VALVE,SS	800	1/2"	1 1/2"	A182 Gr.F304	SS 304+STELLITED	FLEXIBLE GRAPHITE	API 602	SW ENDS,B16.11	
VG	SKD430	GATE VALVE, SS	150	2"	10"	A351 Gr.CF8	SS 304	FLEXIBLE GRAPHITE	API 600	FLGD, B16.5, RF	
VG	SKD430G	GATE VALVE, SS,GO	150	12"	24"	A351 Gr.CF8	SS 304	FLEXIBLE GRAPHITE	API 600	FLGD, B16.5, RF	6
VGA	SKD431	GATE VALVE, SS	300	3"	3"	A351 Gr.CF8	SS 304	FLEXIBLE GRAPHITE	API 600	FLGD, B16.5, RF	22
VGB	SID431	GATE VALVE, SS	300	1 1/2"	2"	A182 F304	SS 304+STELLITED	FLEXIBLE GRAPHITE	API 600	FLGD, B16.5, RF	24
VGC	SID430	GATE VALVE, SS	150	1 1/2"	2"	A 182 F304	SS 304+STELLITED	FLEXIBLE GRAPHITE	API 600	FLGD, B16.5, RF	24
VGL	SIX424L	GATE VALVE,SS,LOCK	800	1"	1 1/2"	A182 Gr.F304	SS 304+STELLITED	FLEXIBLE GRAPHITE	API 602	SW ENDS,B16.11	65
VGL	SKD430L	GATE VALVE, SS, LOCK	150	2"	10"	A351 Gr.CF8	SS 304	FLEXIBLE GRAPHITE	API 600	FLGD, B16.5, RF	65
VGL	SKD430GL	GATE VALVE, SS,GO,LOCK	150	12"	24"	A351 Gr.CF8	SS 304	FLEXIBLE GRAPHITE	API 600	FLGD, B16.5, RF	65
VH	VHD430	PLUG VALVE,SS	150	1/2"	2"	A351 Gr.CF8	SS 304	FLEX+GRPH+BRD+RING	API 599	FLGD, B16.5, RF	87
VHL	VHD430L	PLUG VALVE,SS,LOCKING ARRANGMT	150	1/2"	4"	A351 Gr.CF8	SS 304	FLEX+GRPH+BRD+RING	API 599	FLGD, B16.5, RF	65
VHL	VHD430GL	PLUG VALVE,SS,GO,LOCKING ARGMT	150	6"	10"	A351 Gr.CF8	SS 304	FLEX+GRPH+BRD+RING	API 599	FLGD, B16.5, RF	65
VK	VKC360	BALL VALVE,LO,SS,FB	150	1/2"	4"	A182 F304/A351 CF8	RPTFE	GRAFOIL	ISO 17292	FLGD B16.5,RF	
VK	VKC360G	BALL VALVE,GO,SS,FB	150	6"	14"	A351 GR.CF8	RPTFE	GRAFOIL	ISO 17292	FLGD B16.5,RF	
VKA	VKC361	BALL VALVE,LO,SS,FB	300	1/2"	4"	A182 F304/A351 CF8	RPTFE	GRAFOIL	ISO 17292	FLGD B16.5,RF	
VKA	VKC361G	BALL VALVE,GO,SS,FB	300	6"	8"	A351 CF8	RPTFE	GRAFOIL	ISO 17292	FLGD B16.5,RF	6
VKB	VKC361L	BALL VALVE,LO,SS,FB,LOCK	300	1/2"	4"	A182 F304/A351 CF8	RPTFE	GRAFOIL	ISO 17292	FLGD B16.5,RF	
VKB	VKC361GL	BALL VALVE,GO,SS,FB,LOCKING	300	6"	8"	A351 CF8	RPTFE	GRAFOIL	ISO 17292	FLGD B16.5,RF	6
VKL	VKC360L	BALL VALVE,LO,SS,FB,LOCKING	150	1/2"	4"	A182 F304/A351GR CF8	RPTFE	GRAFOIL	ISO 17292	FLGD B16.5,RF	65
VKL	VKC360GL	BALL VALVE,GO,SS,FB,LOCKING	150	6"	8"	A358 GR.F304	RPTFE	GRAFOIL	ISO 17292	FLGD B16.5,RF	65
VKM	VKC360M	BALL VALVE,LO,SS,FB	150	1/2"	4"	A182 F304/A351 CF8	SS304	GRAFOIL	ISO 17292	FLGD B16.5,RF	
VKM	VKC360MG	BALL VALVE,GO,SS,FB	150	6"	8"	A351 GR.CF8	SS304	GRAFOIL	ISO 17292	FLGD B16.5,RF	
VKN	VKC360ML	BALL VALVE,LO,SS,FB,LOCKING	150	1/2"	4"	A182 F304/A351GR CF8	SS304	GRAFOIL	ISO 17292	FLGD B16.5,RF	
VKN	VKC360MGL	BALL VALVE,GO,SS,FB,LOCKING	150	6"	8"	A358 GR.F304	SS304	GRAFOIL	ISO 17292	FLGD B16.5,RF	
VKO	VKC361M	BALL VALVE,LO,SS,FB	300	1/2"	4"	A182 F304/A351 CF8	SS304	GRAFOIL	ISO 17292	FLGD B16.5,RF	22
VC	R X424	PISTON LIFT CHK VALVE,SS	800	1/2"	1 1/2"	A182 Gr.F304	SS 304+STELLITED		BS EN ISO 15761	SW ENDS, B16.11	
VC	RKD430	SWING CHK VALVE,SS	150	2"	24"	A351 GR.CF8	SS 304		BS 1868	FLGD,B16.5, RF	
VCA	R X424S	PISTON CHK VALVE,SS,SOFT SEAT	800	1/2"	1 1/2"	A182 Gr.F304	VITON ELASTOMER		BS EN ISO 15761	SW ENDS, B16.11	14

1	12-08-22										
Revision	Date	Name	Checked	Description	Revision	Date	Name	Checked	Description		

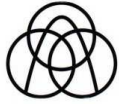

thyssenkrupp
Industrial Solutions

Piping Specification

Piping Class: A1K

IOCL EPCM-3

Projectnumber : 66-6746
 Part : 4
 Page : 20
 Print Date : 17.01.2023
 Print Time : 15:51

Valves	Designation	Rating Class	DN		Body	M a t e r i a l		Packing	Standard	End Connection	Note
			from	to		Body Seat					
VY	Y D430	150	1/2"	2"	A351 GR CF8				MFG STD	FLGD,B16.5,RF	
VYA	YH 360	150	1/2"	24"	A240 Gr.304				EIL		
VYB	YSZ431	150	2"	2"	A403 GR.WP304-S				EIL STD	BW ENDS, SCH 40S	
VYB	YSZ430	150	3"	8"	A403 GR.WP304-S				EIL STD	BW ENDS, SCH 10S	
VYB	YSZ430W	150	10"	24"	A403 GR.WP304-W				EIL STD	BW ENDS, SCH 10S	



Notes

- 14 - TO BE USED IN PP AREA ONLY AS PER SPECIFIC NOTE IN P&ID
- 1 - FOR TYPE OF BRANCH REFER PART3
- 22 - FOR CLASS 300
- 24 - USE SWAGES FOR REDUCING BUTT WELDING SIZES TO SOCKET WELDING SIZES.



- 2 - FOR CLASS 600
- 3 - GEAR OPERATED VALVES
- 41 - FOR CL. 600 FLANGES
- 65 - VALVE WITH LOCKING ARRANGEMENT
- 6 - GEAR OPERATED



- 87 - USE UPTO TEMP. 200 DEG.C.APPLI CABLE FOR VALVE PACKING ALSO
- 90 - FOR IC HOOK UP CONNECTIONS

Revision	Date	Name	Checked	Description	Revision	Date	Name	Checked	Description
1	12-08-22								

Plant PP and CDWU Block	Client IOCL, PANIPAT REFINERY	Contract Code RHQ, EPCM-3 (P-25)	Document ID 6746-PIP-000-EC-0005	Contract No. 66-6746
	TECHNICAL REQUIREMENTS FOR PIPES, FITTINGS, FLANGES, GASKETS & FASTENERS			
	Rev	00	Page	



<p>tkIS India / Vendor</p> <p>Category Codes (Submission Purpose)</p> <table style="width: 100%;"> <tr><td><input type="checkbox"/></td><td>1</td><td>For Approval</td></tr> <tr><td><input type="checkbox"/></td><td>2</td><td>For Review / Comments</td></tr> <tr><td><input type="checkbox"/></td><td>3</td><td>For Information</td></tr> <tr><td><input type="checkbox"/></td><td>4</td><td>For Engineering</td></tr> <tr><td><input type="checkbox"/></td><td>5</td><td>For Enquiry</td></tr> <tr><td><input type="checkbox"/></td><td>6</td><td>For Order Placement</td></tr> <tr><td><input type="checkbox"/></td><td>7</td><td>Final & Approved</td></tr> <tr><td><input type="checkbox"/></td><td>8</td><td>Released for Construction</td></tr> </table> <hr/> <p>Acceptance Codes (Approval Codes)</p> <table style="width: 100%;"> <tr><td><input type="checkbox"/></td><td>1</td><td>Approved</td></tr> <tr><td><input type="checkbox"/></td><td>2</td><td>Approved for Manufacturing / Fabrication with Comments as marked</td></tr> <tr><td><input type="checkbox"/></td><td>3</td><td>Not Approved / Resubmit</td></tr> <tr><td><input type="checkbox"/></td><td>4</td><td>Retained for Information / Records</td></tr> <tr><td><input type="checkbox"/></td><td>5</td><td>Reviewed</td></tr> <tr><td><input type="checkbox"/></td><td>6</td><td>Reviewed as Noted / Resubmit</td></tr> </table> <p>Remarks for AC2 : This marked-up drawings is hereby approved for fabrication / manufacturing and shall be re-submitted after revision. This drawing should be revised only to the extent of tkIS India / Owner / Client comments. Any other changes made by you will not be considered unless clearly highlighted in covering letter asking for approval.</p> <p>This approval / review does not absolve the supplier from the full responsibility for design and fabrication.</p> <p>Date : ___/___/___ Name : _____</p>	<input type="checkbox"/>	1	For Approval	<input type="checkbox"/>	2	For Review / Comments	<input type="checkbox"/>	3	For Information	<input type="checkbox"/>	4	For Engineering	<input type="checkbox"/>	5	For Enquiry	<input type="checkbox"/>	6	For Order Placement	<input type="checkbox"/>	7	Final & Approved	<input type="checkbox"/>	8	Released for Construction	<input type="checkbox"/>	1	Approved	<input type="checkbox"/>	2	Approved for Manufacturing / Fabrication with Comments as marked	<input type="checkbox"/>	3	Not Approved / Resubmit	<input type="checkbox"/>	4	Retained for Information / Records	<input type="checkbox"/>	5	Reviewed	<input type="checkbox"/>	6	Reviewed as Noted / Resubmit	<p>tkIS India / Owner / Client</p> <p>Category Codes (Submission Purpose)</p> <table style="width: 100%;"> <tr><td><input type="checkbox"/></td><td>1</td><td>For Approval</td></tr> <tr><td><input type="checkbox"/></td><td>2</td><td>For Review / Comments</td></tr> <tr><td><input type="checkbox"/></td><td>3</td><td>For Information</td></tr> <tr><td><input checked="" type="checkbox"/></td><td>4</td><td>For Engineering</td></tr> <tr><td><input type="checkbox"/></td><td>5</td><td>For Enquiry</td></tr> <tr><td><input type="checkbox"/></td><td>6</td><td>For Order Placement</td></tr> <tr><td><input type="checkbox"/></td><td>7</td><td>Final & Approved</td></tr> <tr><td><input type="checkbox"/></td><td>8</td><td>Released for Construction</td></tr> </table> <hr/> <p>Acceptance Codes (Approval Codes)</p> <table style="width: 100%;"> <tr><td><input type="checkbox"/></td><td>1</td><td>Approved</td></tr> <tr><td><input type="checkbox"/></td><td>2</td><td>Approved for Manufacturing / Fabrication with Comments as marked</td></tr> <tr><td><input type="checkbox"/></td><td>3</td><td>Not Approved / Resubmit</td></tr> <tr><td><input type="checkbox"/></td><td>4</td><td>Retained for Information / Records</td></tr> <tr><td><input type="checkbox"/></td><td>5</td><td>Reviewed</td></tr> <tr><td><input type="checkbox"/></td><td>6</td><td>Reviewed as Noted / Resubmit</td></tr> </table> <p>Date : ___/___/___ Name : _____</p>	<input type="checkbox"/>	1	For Approval	<input type="checkbox"/>	2	For Review / Comments	<input type="checkbox"/>	3	For Information	<input checked="" type="checkbox"/>	4	For Engineering	<input type="checkbox"/>	5	For Enquiry	<input type="checkbox"/>	6	For Order Placement	<input type="checkbox"/>	7	Final & Approved	<input type="checkbox"/>	8	Released for Construction	<input type="checkbox"/>	1	Approved	<input type="checkbox"/>	2	Approved for Manufacturing / Fabrication with Comments as marked	<input type="checkbox"/>	3	Not Approved / Resubmit	<input type="checkbox"/>	4	Retained for Information / Records	<input type="checkbox"/>	5	Reviewed	<input type="checkbox"/>	6	Reviewed as Noted / Resubmit
<input type="checkbox"/>	1	For Approval																																																																																			
<input type="checkbox"/>	2	For Review / Comments																																																																																			
<input type="checkbox"/>	3	For Information																																																																																			
<input type="checkbox"/>	4	For Engineering																																																																																			
<input type="checkbox"/>	5	For Enquiry																																																																																			
<input type="checkbox"/>	6	For Order Placement																																																																																			
<input type="checkbox"/>	7	Final & Approved																																																																																			
<input type="checkbox"/>	8	Released for Construction																																																																																			
<input type="checkbox"/>	1	Approved																																																																																			
<input type="checkbox"/>	2	Approved for Manufacturing / Fabrication with Comments as marked																																																																																			
<input type="checkbox"/>	3	Not Approved / Resubmit																																																																																			
<input type="checkbox"/>	4	Retained for Information / Records																																																																																			
<input type="checkbox"/>	5	Reviewed																																																																																			
<input type="checkbox"/>	6	Reviewed as Noted / Resubmit																																																																																			
<input type="checkbox"/>	1	For Approval																																																																																			
<input type="checkbox"/>	2	For Review / Comments																																																																																			
<input type="checkbox"/>	3	For Information																																																																																			
<input checked="" type="checkbox"/>	4	For Engineering																																																																																			
<input type="checkbox"/>	5	For Enquiry																																																																																			
<input type="checkbox"/>	6	For Order Placement																																																																																			
<input type="checkbox"/>	7	Final & Approved																																																																																			
<input type="checkbox"/>	8	Released for Construction																																																																																			
<input type="checkbox"/>	1	Approved																																																																																			
<input type="checkbox"/>	2	Approved for Manufacturing / Fabrication with Comments as marked																																																																																			
<input type="checkbox"/>	3	Not Approved / Resubmit																																																																																			
<input type="checkbox"/>	4	Retained for Information / Records																																																																																			
<input type="checkbox"/>	5	Reviewed																																																																																			
<input type="checkbox"/>	6	Reviewed as Noted / Resubmit																																																																																			

00	IFI	Issued for Engineering	14-10-21		14-10-21		14-10-21		-
Rev.	Status	Description	Date	Prepared	Date	Checked	Date	Approved	AC
<p>© thyssenkrupp Industrial Solutions (India) Private Limited 2021</p>									Category Code: - 5

Plant PP and CDWU Block	Client IOCL, PANIPAT REFINERY	Contract Code RHQ, EPCM-3 (P-25)	Document ID 6746-PIP-000-EC-0005	Contract No. 66-6746	
	TECHNICAL REQUIREMENTS FOR PIPES, FITTINGS, FLANGES, GASKETS & FASTENERS				
					Rev



Contents:

1	GENERAL.....	3
2	INSPECTION AND TEST	6
3	RADIOGRAPHY	8
4	HYDROTEST	8
5	MARKINGS	8
6	PACKING AND PRESERVATION.....	8

Plant PP and CDWU Block	Client IOCL, PANIPAT REFINERY	Contract Code RHQ, EPCM-3 (P-25)	Document ID 6746-PIP-000-EC-0005	Contract No. 66-6746	
	TECHNICAL REQUIREMENTS FOR PIPES, FITTINGS, FLANGES, GASKETS & FASTENERS				
					Rev

1 GENERAL

- 1.1 Unless otherwise specified, for order quantity > 3meters, pipes shall be supplied in single random lengths of 4-7 meters. At the time of supply, positive quantity tolerance of maximum one single random length of 4 – 7m is acceptable. However, negative quantity tolerance is NOT acceptable.
- 1.2 In case of low temperature carbon steel pipes, fittings and flanges, material certificates for impact test as per relevant codes shall be furnished.
- 1.3 All socket weld and slip-on flanges shall suit pipe OD as per ASME B36.10M / ASME B36.19M.
- 1.4 Slip-on flanges NS 4" & above shall have 1/8" diameter drilled hole through the hub for venting of gases during welding.
- 1.5 The surface finish for flanges shall be obtained by cylindrical machining so that no radial tool marks are created on the finish surface during machining.
- 1.6 All gasket design shall be such that the gasket factor (m) and minimum gasket design seating stress (y) shall conform to the requirements of ASME B16.5.
- 1.7 Unless otherwise specified, all threaded items shall have NPT threads as per ASME B 1.20.1.
- 1.8 For pipes, fittings and flanges required to be galvanised, the zinc coating shall be in accordance with ASTM A123.
- 1.9 For welded tees (longitudinally welded), set-on type branching is not permissible.
- 1.10 In case of fasteners, the first size specified indicates bolt / stud diameter in inches and second dimension indicates length in mm.
- 1.11 Unless otherwise specified, spiral wound gaskets shall have inner & outer ring construction. Inner ring bore shall be equal to pipe bore.
- 1.12 All SW flanges & fittings should be as per ASME B16.11.
- 1.13 All BW ends should be as per ASME B16.25.
- 1.14 For stud bolts, rolled / formed threads are only allowed (no cut threads).
- 1.15 For bolts, heat treatment & threading sequence shall be as specified in the applicable codes.
- 1.16 Fasteners & washers, if required galvanized, the galvanizing shall be as per ASTM A153.
- 1.17 For Fasteners:
- 1.17.1 Thread std. (bolt): ASME B1.1 CL.2A / Thread std. (Nut): ASME B1.1 CL.2B.
- 1.17.2 UNC thd. for ≤ 1" dia & UN8 thd. for > 1" dia.
- 1.17.3 End machining of Studs shall be to DIN 976 Type B / ISO 4753 (chamfered ends).
- 1.18 Any conflict between this document and technical specification, the latter shall govern.
- 1.19 The technical part of the offer must consist of tkIS (India) Technical Specification for the particular item in which the vendor has to mark clearly 'YES' against each line of the specification sheet under the column "Bidder's Comments", in case the bidder is taking a deviation from tkIS (India) spec. The bidder should clearly state the alternative offered. Deviations indicated anywhere else will not be entertained. The sheet must bear the seal and signature of the bidder in the technical specification sheet.

Plant PP and CDWU Block	Client IOCL, PANIPAT REFINERY	Contract Code RHQ, EPCM-3 (P-25)	Document ID 6746-PIP-000-EC-0005	Contract No. 66-6746
	TECHNICAL REQUIREMENTS FOR PIPES, FITTINGS, FLANGES, GASKETS & FASTENERS			
	Rev	00	Page	

1.20 Tolerance for components shall be as per applicable codes.

1.21 All welded pipes & fittings shall have max. longitudinal welding seams as stated below:

<u>Nom. Size</u>	<u>Pipes</u>	<u>Fittings</u>
< 36"	Max. 1 longitudinal welding seam	Max. 1 longitudinal welding seam
36" – 48"	Max. 2 longitudinal welding seams	Max. 2 longitudinal welding seams
50" – 72"	Max. 3 longitudinal welding seams	Max. 4 longitudinal welding seams
> 72"	Max. 4 longitudinal welding seams	Max. 4 longitudinal welding seams

Circumferential welding seams are not permitted.

For parts with welding factor E=1.00, the welding seams shall be 100% radiographed.

WPS / PQR / WPO shall be reviewed by IOCL approved TPIA.

1.22 The carbon percentage shall be as per individual ASTM material grade and any other special requirements if specified (e.g. IBR, NACE, Hydrogen service etc.)

1.23 Unless specifically exempted, welded pipes shall be acceptable only with longitudinal weld made employing automatic welding.

1.24 For reducing BW fittings having different wall thickness at each end, the greater one shall be employed and the ends shall be matched to suit respective thickness.

1.25 All welded fittings shall be double welded. Inside weld projection shall not exceed 1.6mm and the welds shall be ground smooth at least 25mm from the ends.

1.26 For fittings made out of welded pipe, the pipe itself shall be of double welded type, manufactured with the addition of filler material and made employing automatic welding only.



1.27 All welded fittings shall be normalised for carbon steel, normalised & tempered for alloy steel and 100% radiographed by X-ray for all welds made by fitting manufacturer as well as for welds on the parent material. Simulation test of plate material to be ensured to meet mechanical properties considering additional heat treatments. RT, DP and hardness testing of welds to be carried out after heat treatment. WPS / PQR / WPO to be reviewed for welded fittings by IOCL approved TPIA.

1.28 Heads of jack screws and machine bolts shall be heavy hexagonal type. Jack screw end shall be rounded.



1.29 For Ring Joint Flanges, Blinds and Spacers, the hardness shall be as follows:

<u>Flange Material</u>	<u>Min. Hardness of Groove (BHN)</u>
Carbon Steel	140
1% Cr to 5% Cr, 1/2 Mo	150
Type 304,316,347,321	160
Type 304L, 316L	140

1.30 For RTJ flanges, blinds & spacers, the hardness of the groove shall be specified on the test report.

Plant PP and CDWU Block	Client IOCL, PANIPAT REFINERY	Contract Code RHQ, EPCM-3 (P-25)	Document ID 6746-PIP-000-EC-0005	Contract No. 66-6746	
	TECHNICAL REQUIREMENTS FOR PIPES, FITTINGS, FLANGES, GASKETS & FASTENERS				
					Rev

- 1.31 For spiral wound gaskets, compressibility and sealability type test to be witnessed by IOCL approved TPIA or to be verified based on the test previously witnessed by any of IOCL approved TPIA for the lot being offered. Filler for spiral wound gasket shall not have any colour or dye.
- 1.32 Full face gaskets shall have bolt holes punched out.
- 1.33 Austenitic stainless steel:
- 1.33.1 All items shall be supplied in solution annealed condition.
- 1.33.2 For all Austenitic Stainless steels, Intergranular Corrosion (IGC) Test shall be conducted as per following:
- ASTM A262 Practice B with acceptance criteria of 60 mils/year (max) for castings
- OR
- ASTM A262 Practice 'E' with acceptance criteria of 'No cracks as observed from 20X magnification' & microscopic structure to be observed from 250 X magnification" for items other than casting.
- For IGC test, two sets shall be drawn from each solution annealing lot; one set corresponding to highest carbon content and other set corresponding to the highest rating/thickness.
- 1.33.3 For all items of stabilised SS grades (SS 321 / 321H / 347 / 347H), stabilizing heat treatment shall also be done. It shall be carried out subsequent to normal solution annealing. Soaking temperature and holding time shall be 900°C and 4hrs respectively.
- 1.34 Stud bolts shall be threaded full length with two heavy hex nuts. The nuts shall be double chamfered, semi-finished, heavy hexagonal type and shall be made by the hot forged process.
- 1.35 All the stud/ bolt should have manufacturer test certificates in case of Alloy / SS metallurgy with identified colour marking at the stud ends/ bolt side face.
- 1.36 All components in "Hydrogen Service" shall comply with requirements of project specification, Doc. 6746-PIP-000-EC-0004.
- 1.37 All components in Sour service (NACE) shall comply with requirements of NACE MR0103 & project specification Doc. No. 6746-PIP-000-EC-0005.
- 1.38 Any conflict between this document, technical specification and enclosures, the most stringent shall govern.
- 1.39 Gaskets – "Flexible graphite" compounds shall contain min. 95% pure carbon grade.
- 1.40 Steel pipe shall be made by open hearth, electric furnace or basic Oxygen process.
Pipe made by acid-bessemer process is not acceptable.
- 1.41 Unless specifically exempted, welded pipes shall be acceptable only with longitudinal weld
Made employing automatic welding.
- 1.42 Spiral welded pipes shall be acceptable.
- 1.43 Unless mentioned otherwise in material code, double seam 180 deg apart is allowed for sizes 36" and larger only.
- 1.44 Galvanised pipes shall be only hot dip galvanised to ASTM A53.



Plant PP and CDWU Block	Client IOCL, PANIPAT REFINERY	Contract Code RHQ, EPCM-3 (P-25)	Document ID 6746-PIP-000-EC-0005	Contract No. 66-6746	
	TECHNICAL REQUIREMENTS FOR PIPES, FITTINGS, FLANGES, GASKETS & FASTENERS				
					Rev

2 INSPECTION AND TEST

Vendor / manufacturer shall have and maintain a quality control system which will establish that all specified requirements including raw material control system, manufacturing, heat treatment, NDT and all other tests will be met. Vendor shall follow standard QAP issued by tkIS (India).

Inspection shall be carried out by IOCL approved Third Party Inspector (TPIA). Vendor shall offer the products for IOCL approved TPIA inspection at manufacturer's place with all necessary calibrated gauges and measuring instruments. The following evaluation / inspection shall be carried out by IOCL approved TPIA as per attached standard QAP:

- 2.1 All shop test certificates and records as defined in the technical specification shall conform to the corresponding ASME / ASTM / API / BS / IBR specifications.
- 2.2 Where corrosion test is specified as a supplementary requirement, it shall be carried out for at least one sample per size / Heat / heat treatment lot (Lot is as defined in ASTM A960).
- 2.3 Review of manufacturing / inspection procedure followed by manufacturer.
- 2.4 Identification / review of raw material test certificate / records.
- 2.5 Review of heat treatment charts.
- 2.6 Review of manufacturer's Test certificates / Reports.
- 2.7 Verification of marking / stamping on each item.
- 2.8 100% visual inspection by IOCL approved TPIA - Surface of fittings shall be free from rust, rust preventive coating, mill scales etc. CS fittings shall be offered in shot blasted condition and SS fittings shall be offered after pickling and passivation. Flanges shall be offered in machined condition before applying rust preventive.
- 2.9 Dimensional inspection: - Manufacturer must ensure that 100% pipes, fittings, flanges, gaskets are dimensionally inspected by them and item wise major dimensions are recorded in an inspection report before offering to IOCL approved TPIA. IOCL approved TPIA will carry out dimensional inspection. Refer standard QAP for extent of inspection by IOCL approved TPIA. Fasteners – Inspection with "GO" and "NO GO" gauge -100% inspection by manufacturer & 10% inspection by IOCL approved TPIA.
- 2.10 Review of chemical & witness random Physical / IGC test etc., as per standard QAP.
- 2.11 Fittings / Flanges shall be subject to hardness test of CS & AS material as per standard QAP.
- 2.12 Butt weld edge preparation of Fittings / Flanges shall be subject to DP test as per standard QAP.
- 2.13 Pipes, Fittings and Flanges of Alloy steel, Stainless steel and Non-Ferrous materials (except carbon steel), shall be subjected to PMI Test as per specification Doc.6-81-0001.
- 2.14 Radiography - Extent of radiography shall be as per applicable code / tkIS (India) specification. All RT films shall be reviewed by manufacturer & offered to IOCL approved TPIA for review.
UT - If specified, 100% examination must be performed by manufacturer & IOCL Approved TPIA shall review the UT report.



Plant PP and CDWU Block	Client IOCL, PANIPAT REFINERY	Contract Code RHQ, EPCM-3 (P-25)	Document ID 6746-PIP-000-EC-0005	Contract No. 66-6746	
	TECHNICAL REQUIREMENTS FOR PIPES, FITTINGS, FLANGES, GASKETS & FASTENERS				
					Rev

- 2.15 Hydro test of Pipes – 100% by manufacturer. For pipes ordered on manufacturer, inspection shall be as per standard QAP. Post / pre order, the % of witness by IOCL approved TPIA may be increased at discretion of IOCL approved TPIA.
- 2.16 No repair is permitted on the base material.
- 2.17 Steel Insert Rubber Gaskets – 100% shall be spark tested at min 15 kV.
PTFE Enveloped Gaskets – 100% shall be spark tested at 5 kV / mm thickness of gasket.
- 2.18 Any non-conformity during sampling inspection will lead to rejection of total lot of material offered for inspection.
- 2.19 100% Pipes, Fittings, Flanges shall be stamped with IOCL approved TPIA control marks after satisfactory inspection. In case of Gaskets and Fasteners – Tags to be stamped by IOCL approved TPIA.
- 2.20 Manufacturer's certificate shall be countersigned by IOCL approved TPIA after satisfactory inspection.
- 2.21 Above requirements are minimum and any other purchase order / project specific requirements must also be fulfilled by the Manufacturer / Vendor.
- 2.22 All measuring gauges and instruments shall have valid calibration certificate.
- 2.23 For IBR items, IBR approved material must be offered to IOCL approved TPIA with original IBR certificate or IBR endorsed certificate. IBR stamped control marks to be verified and reported in their inspection report by IOCL approved TPIA.
- 2.24 Above requirements are minimum and any additional purchase order / project specification requirements shall be fulfilled by Manufacturer / Supplier.
- 2.25 Client or its authorized representative shall reserve the right to vet and suggest changes in vendor's procedures.
- 2.26 Inspection Release Note with Inspection Report by IOCL approved TPIA and supporting Material Test Certificates shall be submitted to tkIS (India) for Dispatch Clearance Certificate, prior to dispatch of items to site.
- 2.27 Inspection shall be carried out by IOCL approved Third Party Inspection Agency (TPIA). It is vendor's responsibility to arrange for third party inspection to be undertaken during execution for the order on behalf of IOCL.

The names of IOCL approved TPIA agencies is listed below:

1. M/s ABS Industrial Verification (India) Pvt. Ltd
2. M/s Bureau Veritas (India) Pvt. Ltd
3. M/s Certification Engineers International Ltd
4. M/s International Certification Services Pvt. Ltd
5. M/s Projects and Development India Ltd. (PDIL)
6. M/s SGS India Pvt Ltd
7. M/s Tata Projects Limited
8. M/s TUV SUD South Asia Pvt Ltd
9. M/s VCS Quality Services Private Limited

Where Inspection is to be performed on Foreign vendors, the Principals of these agencies in Foreign country shall be used.

Plant PP and CDWU Block	Client IOCL, PANIPAT REFINERY	Contract Code RHQ, EPCM-3 (P-25)	Document ID 6746-PIP-000-EC-0005	Contract No. 66-6746	
	TECHNICAL REQUIREMENTS FOR PIPES, FITTINGS, FLANGES, GASKETS & FASTENERS				
					Rev

2.28 All certification for supplied material shall be in accordance with European Standard EN 10204. Certificates shall be available at the time the materials are ready for inspection. Certificates as a minimum shall provide information as per enclosed Table 1.

3 RADIOGRAPHY

- 3.1 For fittings, 10% radiography means 10% of the quantity ordered per tag size, per heat, per lot per visit & for pipes, 10% radiography means 10% of the running pipe length per heat lot / per size / per visit.
- 3.2 100% radiography means entire quantity for all sizes has to be radiographed.
- 3.3 Where extent of radiography is specified as 300mm per pipe length, it shall be distributed at least two places along the pipe length.

4 HYDROTEST



- 4.1 Hydrotest for the pipes shall be as defined under Clause 22 of ASTM A530 or Clause 22.2 of ASTM A999 as applicable. Potable water shall be used for testing of Carbon steel & Alloy steel items. For testing of Stainless Steel items, maximum chlorine content in water shall be 15-20 ppm.

5 MARKINGS



- 5.1 Pipes, flanges and fittings shall be furnished with weatherproof marking as per respective technical specification sheets. However, for nominal size DN 25 and below, the code no. & size shall be minimum specified and other details should be furnished with a metal tag in the packing box.
- 5.2 As far as possible hard stamping shall be avoided for wall thickness less than 3.2mm. Any other suitable means of identification shall be used instead. Light metals, like Al, Ti, Ni, Monel and Hastelloy should not be hard stamped.
- 5.3 All other requirements for certification, marking and colour coding of bulk piping materials as per specification Doc. 6-82-0003 shall be complied.

6 PACKING AND PRESERVATION

- 6.1 Machined surfaces of flanges and all threaded and welding ends shall be protected against damage during transit and storage. For flanges the machined surfaces shall be coated with easily removable rust preventive grease or protective coating and the surface shall then be covered with heavy-duty plastic or wooden or metallic covers.
- 6.2 Where wood fibre or metal covers are used, plastic sheet shall be placed between the flange and the cover for additional protection.
- 6.3 Varnish or other suitable protective coating to be applied to pipes, fittings and flanges before delivery to protect during shipment and storage at site.
- 6.4 Packing should be sea worthy for items intended to be transported by ship, Air freight (as per the PO requirements).

Plant PP and CDWU Block	Client IOCL, PANIPAT REFINERY	Contract Code RHQ, EPCM-3 (P-25)	Document ID 6746-PIP-000-EC-0005	Contract No. 66-6746	
	TECHNICAL REQUIREMENTS FOR PIPES, FITTINGS, FLANGES, GASKETS & FASTENERS				
					Rev



- 6.5 All pipes shall be supplied thoroughly drained, dried and cleaned from inside and with ends plugged properly. To avoid damage of pipe ends prior to dispatch. IOCL approved TPIA shall verify and record in report prior to issue of release order for all packing requirements.
- 6.6 Pipes, Flanges, Fittings, Fasteners and Gaskets shall be dry, clean and free from moisture, dirt and loose foreign materials of any kind.
- 6.7 Packing inspection: Following to be ensured prior to shipment from supplier.
- 6.7.1 After inspection and testing, the piping items shall be properly packed in wooden boxes to avoid transportation damage. Socket weld/screwed ends shall be closed using plastic caps. The wooden case should be properly covered or wrapped by tarpaulin or by any kind waterproof and strong plastic foil.
- 6.7.2 Packing shall be such that no free movement within packed wooden or metallic crates/boxes and no damage to paint/rust preventive shall happen until receipt at site. Materials shall be protected against corrosion during transit as necessary. Wood shavings and other paper shall not be used for padding or cushioning. Gunny bag packing are not permitted. Nested packing of piping bulk items shall be avoided.
- 6.7.3 Inspection release note, list of spares, list of loose items shall be included inside the packing and outside the packing along with material to site.
- 6.7.4 All consignment must be properly packed & accompanied with proper documents such as LR copy with weight, delivery note, Invoice copy, release order, and MTC etc.
- 6.7.5 Packages containing "FRAGILE" articles shall be appropriately packed and in addition to the words "Fragile-Handle With Care" being stencilled on two opposite sides, internationally recognized symbols shall also be used "This Side Up".
- 6.7.6 "Mandatory spare", which shall be individually tagged, must be covered with a suitable preservative and wrapped with grease proof paper and be packed in separate cases from the prime item. The cases are to bear the markings as specified and in addition the words "Mandatory Spare." Commissioning spares shall be individually tagged and marked "COMMISSIONING SPARES" and shall be packed and shipped with the prime item.
- 6.7.7 Photos before and after packing shall be submitted for review and records.
- 6.8 Preservation: Following to be ensured prior to shipment from supplier.
- 6.8.1 All weather protection is required in such a way rain water should not enter inside the package.
- 6.8.2 After the pickling and drying, Piping bulk items should be preserved in clean and dry condition to prevent entry of moisture, dust or dirt.
- 6.8.3 Piping bulk items shall be protected from rust, corrosion and mechanical damage during transportation, shipment and storage.
- 6.8.4 Rust preventive used on machined surfaces to be welded shall be easily removable with a petroleum solvent and the same shall not be harmful/ detrimental to welding.
- 6.8.5 An adequate quantity of moisture absorbent (silica gel) shall be added to protect the contents for sufficiently long time from corrosion.

Plant PP and CDWU Block	Client IOCL, PANIPAT REFINERY	Contract Code RHQ, EPCM-3 (P-25)	Document ID 6746-PIP-000-EC-0005	Contract No. 66-6746
	TECHNICAL REQUIREMENTS FOR PIPES, FITTINGS, FLANGES, GASKETS & FASTENERS			
	Rev	00	Page	

- 6.8.6 All bright and machined parts shall be coated with a recognized rust preventative suited to the particular application concerned. Ensure application of rust protective coating on Bolt and Nuts fitted with the equipment's to prevent rusting during storage.
- 6.9 Both ends of the Pipe, Ends of Fittings, RF of Flanges shall be protected with the following material:
- 6.9.1 Plain end of Pipes, RF of Flanges: Plastic cap
- 6.9.2 Bevel end of Pipes/Fittings: Wood, Metal or plastic cover
- 6.9.3 Threaded end of Pipes/Fittings: Metal or plastic threaded cap
- 6.9.4 End protectors to be used on bevelled ends shall be securely and tightly attached with belt or binding wire.
- 6.9.5 Steel end protectors to be used on galvanized pipes shall be galvanized. Plastic caps can also be used as end protector for galvanized pipe ends.
- 6.10 Vendor shall ensure that item shall reach site in the as released condition in shop floor without any damages. In case of any damage observed upon receipt at site, the item shall be replaced without any cost & time implication by supplier.

TABLE 1

	Pipe	Fitting	Plate	Forging	Bolts	Weld Consumable
STANDARDS						
Material / Design Grade	✓	✓	✓	✓	✓	✓
Welding Process	✓	✓	X	X	X	X
Heat Treatment	✓	✓	✓	✓	✓	X
IDENTIFICATION						
Mills/Manufacture Name / Symbol	✓	✓	✓	✓	✓	✓
Certificate Number	✓	✓	✓	✓	✓	✓
Traceable Numbers	✓	✓	X	✓	X	X
Date of Issue	✓	✓	✓	✓	✓	✓
Charge / Batch Number	✓	✓	✓	✓	✓	✓
Service Rating	X	X	X	✓	X	X
Dimensions (Size/Diam./Sched)	✓	✓	✓	✓	✓	X
DATA						
Mech. Properties	✓	✓	✓	✓	✓	✓
Chemical Analysis	✓	✓	✓	✓	✓	✓
No. of Samples Tested	✓	✓	✓	✓	X	X
Temperature of Heat Treatment	✓	✓	✓	✓	✓	X
ORDER REFERENCE						

Plant PP and CDWU Block	Client IOCL, PANIPAT REFINERY	Contract Code RHQ, EPCM-3 (P-25)	Document ID 6746-PIP-000-EC-0005	Contract No. 66-6746	
	TECHNICAL REQUIREMENTS FOR PIPES, FITTINGS, FLANGES, GASKETS & FASTENERS				
					Rev

Purchase Order No./	√	√	√	√	√	√
Item Number						
Quantity	√	√	√	√	√	√

√ = Mandatory X = Non-Mandatory / Not Required

Notes:

1. When hydrostatic testing, test pressure and test result shall be recorded.
2. Charge number is same as heat numbers for castings. When batch number is indicated, it shall be traceable to the heat / charge number. In case of forgings, the forging number / batch number shall be traceable to the heat number of the base material.
3. The traceable number shall be clearly indicated on the relevant Material Certificate.
4. In compliance with the appropriate AWS filler metal specification.
5. Required when pipe or fitting is manufactured with a weld seam.



ENGINEERING DESIGN BASIS (PIPING)

RHQ-EC-ML-0001
2021
PAGE 36 OF 94
REV 01

ENGINEERING CELL
PROJECT DEPARTMENT- RHQ

2	Positive Material Identification	Positive Material identification (PMI) check shall be done at all three stages and the same shall be incorporated in the ITP for fabrication jobs. Random cross check of PMI data shall be done by IOCL during site construction. (Clause incorporated as per Inspection RTF Recommendations -2019)
---	----------------------------------	---

4.0 SPECIFIC DESIGN REQUIREMENTS

4.1 HYDROGEN SERVICE REQUIREMENTS

4.1.1 PIPES, FITTINGS AND FLANGES

S.No.	Project Philosophy
1	All carbon steel pipes, fittings and flanges having wall thickness 9.53 mm and above shall be normalised. Cold drawn pipes and fittings shall be normalized after the final cold draw pass for all thicknesses. In addition, fittings made from forgings shall have Carbon - 0.35% max. and Silicon - 0.35% max. The normalising heat treatment shall be a separate heating operation and not a part of the hot forming operation.
2	All alloy steel (Cr-Mo) pipes, forgings and fittings shall be normalised and tempered. The normalising and tempering shall be a separate heating operation and not a part of the hot forming operation. The maximum room temperature tensile strength shall be 100,000 psi.
3	For carbon steel pipes, fittings and flanges, hardness of weld and HAZ shall be 200 BHN (max.). For alloy steel, hardness of weld and HAZ shall be 225 BHN (max.).
4	For all Carbon steel and Alloy steel pipes, fittings and flanges with wall thickness over 20mm, Charpy-V Notch impact testing shall be carried out in accordance with paragraph UG-84 of ASME Section VIII, Div-1 for weld metal and base metal from the thickest item per heat of material and per heat treating batch. Impact test specimen shall be in complete heat treated condition and accordance with ASTM A370. Impact energies at 0°Celsius shall average greater than 27J (20 ft-lb) per set of three specimens, with a minimum of 19J (15 ft-lb). If welding is used in manufacture, impact testing of Heat Affected Zone (HAZ) & weld metal shall also be carried out.
5	All carbon steel pipes and fittings having wall thickness 19 mm and above shall be post weld heat treated. All alloy steel (Cr-Mo) pipes and fittings shall be post weld heat treated irrespective of type or thickness of weld. All austenitic stainless steel grades shall be solution annealed after welding. 100% radiography of welded joints shall be done both before and after PWHT.

4.1.2 VALVES

4.1.2.1 GENERAL

S.No.	Project Philosophy
1	All valve castings shall be of radiographic quality. All cast valve flanges & bodies with flange rating of class 900 or greater shall be examined in accordance with paragraphs 7.2 through 7.5 of Appendix-7 of ASME SEC-VIII, DIV.1, regardless of casting quality factor.



ENGINEERING DESIGN BASIS (PIPING)

RHQ-EC-ML-0001
2021
PAGE 37 OF 94
REV 01

ENGINEERING CELL
PROJECT DEPARTMENT- RHQ

Only Normalized and Tempered material shall be used in the following specifications:

Castings : A217 Gr.WC1, A217 Gr.WC4, A217 Gr.WC5, A217 Gr.WC6, A217 Gr.WC9, A217 Gr.C5, A217 Gr.C12
Forgings : A182 Gr.F11 Cl.2

4.1.2.2 HELIUM LEAK TEST

Body/bonnet/cover joints & stuffing box of all valves shall have low emission. One valve per metallurgy, per rating, per size shall be helium leak tested as per ASME Sec. V, Subsection A, Article 10 (Detector Probe Technique), Appendix IV at a minimum of 25% of the allowable (rated) cold working pressure. Selection of valves for helium leak test shall be at random. Test duration shall be as follows:

S.No.	PRESSURE CLASS	NOMINAL SIZE	TEST DURATION (in Minutes)
1	Upto 300	Upto 2"	3
2	Upto 300	3" to 6"	6
3	Upto 300	8" to 16"	9
4	Upto 300	18" to 24"	9
5	600	Upto 2"	6
6	600	3" to 6"	9
7	600	8" to 16"	9
8	600	18" to 24"	12
9	800 & 900	Upto 2"	9
10	800 & 900	3" to 6"	12
11	800 & 900	8" to 16"	12
12	800 & 900	18" to 24"	15
13	1500	Upto 2"	12
14	1500	3" to 6"	15
15	1500	8" to 16"	15
16	1500	18" to 24"	18
17	2500	Upto 2"	12
18	2500	3" to 6"	18
19	2500	8" to 16"	18
20	2500	18" to 24"	21

The valve shall show no leakage. No leakage is defined as a total leakage rate of less than 0.0001 ml/s of helium.

4.1.2.3 CS & AS VALVES

S.No.	Project Philosophy
1	Bend test and Magnetic Particle inspection of the entire surface of body and bonnet casting shall be in accordance with ASTM A217. Supplementary requirement S3 & S4



ENGINEERING DESIGN BASIS (PIPING)

RHQ-EC-ML-0001
2021
PAGE 38 OF 94
REV 01

ENGINEERING CELL
PROJECT DEPARTMENT- RHQ

evaluation of magnetic particle, inspection shall be in accordance with MSS-SP- 53 except that no linear discontinuities shall be allowed. The Brinell hardness of heat-treated casting shall not exceed 200 BHN for carbon steel & 225 for alloy steel.

Repair of defective casting shall be outlined in writing to the purchaser before repair starts. Repair method to be approved prior to welding.

Casting shall be preheated to a minimum of 400°F prior to welding and all Chromium-Molybdenum alloys shall be post-weld heat treated after welding is complete. Stress relieving is essential for welds.

Carbon steel shall be normalized, and alloy steels shall be normalized & tempered. Dye Penetrant test of welds shall be in accordance with ASTM B165 Procedure B-2. Interpretation as per Appendix-8 of ASME-VIII Div.1.

The tensile stress for AS shall be less than 100,000 psi.

Charpy V-notch impact testing is to be done for valve material (average 20 ft-lb for set of 3 [minimum value 15 ft-lb] at 30 F).

For radiography and acceptance criteria of Valve castings, refer Para. 2 of Clause 4.1.2.4(1)

4.1.2.4 SS VALVES

S.No.	Project Philosophy
1	<p>Casting and test bar shall be heat treated together. Valve casting shall be in solution heat treated and pickled condition.</p> <p>Critical body and bonnet casing section typically defined by ASME B16.34 shall be radiographed and shall meet ASTM E446 (upto 2" thick) Category A,B & CA Level 2, Category CB, OC & CD Level 3, Category D,B & F Level 0. For wall thickness 2" to 4.5" comparable plates of ASTM E186 shall be used. ASTM E94 and ASTM E142 shall be used for recommended practice & controlling quality of radiography as guide. The entire surface of all castings shall be dye-penetrant inspected after pickling.</p> <p>Repair welds shall be 100% radiographed and evaluated in accordance with paragraph 344.5 of ASME B31.3 with a minimum casting quality factor of 0.95. Dye Penetration test shall be as per ASTM E165 Procedure B-2, Interpretation as per Appendix-8 of ASME-VIII Div.1.</p>

4.2 TECHNICAL REQUIREMENTS FOR PIPING MATERIAL

This is applicable over and above the requirements specified in Clause 3.8.

4.2.1 GENERAL

S.No.	Type	Description
1	Ends : Unless otherwise specified, the	SW/SCRD : ASME B16.11

The drawing, design and details given on this format are the property of ENGINEERS INDIA LIMITED. They are merely loaned on the borrower's express agreement that they will not be reproduced, copied, exhibited or used, except in the limited way permitted by a written consent given by the lender to the borrower for the intended use.

विक्रेता कार्यशाला में
स्वीकारात्मक सामग्री पहचान
के लिए मानक विनिर्देश

**STANDARD SPECIFICATION
FOR
POSITIVE MATERIAL IDENTIFICATION
(PMI)
AT VENDOR'S WORKS**

REV.	DATE	REVISIONS	BY	CHECKED	CONVENOR	CHAIRMAN (S/B.)
0	07-12-2000	ISSUED AS STANDARD SPECIFICATION	<i>[Signature]</i>	<i>[Signature]</i>	<i>[Signature]</i>	<i>[Signature]</i>



ENGINEERS INDIA LIMITED
NEW DELHI

**STANDARD SPECIFICATION FOR
POSITIVE MATERIAL
IDENTIFICATION (PMI) AT
VENDOR'S WORKS**

SPECIFICATION

6-81-0001

REV.

0

The drawing, design and details given on this format are the property of ENGINEERS INDIA LIMITED. They are merely loaned on the borrower's express agreement that they will not be reproduced, copied, exhibited or used, except in the limited way permitted by a written consent given by the lender to the borrower for the intended use.

CONTENTS

- 1.0 SCOPE**
- 2.0 REFERENCE DOCUMENTS**
- 3.0 DEFINITIONS**
- 4.0 PMI EXAMINATION**
- 5.0 ACCEPTABLE METHODS FOR PMI**
- 6.0 EXTENT OF PMI EXAMINATION**
- 7.0 RECORDING AND DOCUMENTATION**
- 8.0 MARKING**



ENGINEERS INDIA LIMITED
NEW DELHI

**STANDARD SPECIFICATION FOR
POSITIVE MATERIAL
IDENTIFICATION (PMI) AT
VENDOR'S WORKS**

SPECIFICATION

6-81-0001

REV.

0

Page 2 of 6

1.0 SCOPE

- 1.1 This specification applies to the requirements for Positive Material Identification (PMI) to be performed at the vendor's works on Metallic Alloy Materials procured either directly by the Owner/EIL/ LSTK contractor or indirectly through the sub-vendors.
- 1.2 Any post order deviation from this specification must be approved by Owner/EIL in the Deviation/ Waiver Permit format (No. 5-0000-0180-F1) enclosed with Material Requisition.
- 1.3 This specification covers the procedures and methodology to be adopted to assure that the chemical composition of the alloy material is consistent with the material specifications as specified in purchase documents using 'Alloy Analyser' at the time of final inspection before dispatch.
- 1.4 The scope of this specification shall include but shall not be limited to Positive Material Identification (PMI) to be performed on Alloy Materials listed below:
 - Alloy Steel Pipes including Clad Pipes
 - Alloy Steel Flanges & Forgings
 - Alloy Steel Fittings including Clad Fittings
 - Alloy Steel Fasteners
 - Alloy Cast & Forged steel valves
 - Alloy Steel Instrumentation Items (Control Valves, Safety Valves etc.)
 - Longitudinal Pipe & Fittings Welds.
 - Gaskets (for Ring Type Joints)

Following items shall be excluded from scope of PMI examination.

- Gaskets other than for Ring Type Joints
 - Internal Components of Valves
- 1.5 All grades of material supplies including Stainless Steels shall be liable for PMI test at site. In case of any defective materials being found at site, the vendor shall be responsible to effect replacement of such defective materials at project site without any delays to the satisfaction of EIL site RCM (Resident Construction Manager).

2.0 REFERENCE DOCUMENTS

- 2.1 API Recommended Practice 578 (First Edition, May 1999)- Material Verification Program for new and Existing Alloy Piping Systems.

3.0 DEFINITIONS

- 3.1 **Vendor:** Any Supplier or Manufacturer on whom an order is placed for the supply of referred items. This definition shall also include any sub-vendor or manufacturer on whom a sub-order is placed by the vendor.
- 3.2 **Inspection Lot:** A group of items offered for inspection covered under same size, Heat and Heat treatment lot.
- 3.3 **Alloy Material:** Any metallic material (including welding filler materials) that contains alloying elements such as chromium, nickel, molybdenum or vanadium, which are intentionally added to enhance mechanical or physical properties and/or corrosion resistance.



ENGINEERS INDIA LIMITED
NEW DELHI

**STANDARD SPECIFICATION FOR
POSITIVE MATERIAL
IDENTIFICATION (PMI) AT
VENDOR'S WORKS**

SPECIFICATION

6-81-0001

REV.

0

4.0 PMI EXAMINATION

- 4.1 The vendor shall submit a procedure of PMI to comply with the requirements of this Specification Approval of PMI Procedure shall be obtained from Owner/EIL/TPI prior to commencing manufacture/ inspection of product.
- 4.2 PMI examination of alloy materials is independent of any certification, markings or colour coding that may exist and is aimed at verifying that the alloy used are as per specified grades.
- 4.3 The Vendor shall identify all incoming alloy materials and maintain full tracability of all alloy materials, including all off-cuts. Transfer of identification marks shall be undertaken prior to cutting to ensure maintenance of identification on off-cuts.
- 4.4 The Vendor shall ensure that all alloy materials are segregated and stored in separately identified locations to prevent the mix up of materials of different alloy specifications or alloy material with carbon steel. Non ferro-magnetic materials shall be segregated at all times from ferro-magnetic materials.
- 4.5 PMI examination is subject to surveillance inspection by Owner/EIL/TPI.

5.0 ACCEPTABLE METHODS FOR PMI

- 5.1 The method used for PMI examination shall provide a quantitative determination of the alloying elements like Cr, Mo, Ni, V in Alloy Steel items.
- 5.2 Instruments or methods used for PMI examination shall be able to provide quantitative, recordable, elemental composition results for positive identification of alloying elements present.
- 5.3 The acceptable instruments for alloy analyser shall be either "Portable X-Ray fluorescence" or "Optical Emission" type each capable of verifying the percentage of alloy elements within specified range.
- 5.4 Chemical spot testing, magnets, alloy sorters and other methods using eddy current or triboelectric testing methods are not acceptable for PMI examination.
- 5.5 The PMI instrument used shall have the sensitivity to detect the alloying elements in the specified range.
- 5.6 All PMI instruments shall have been serviced within a 6 month period of the time of use to verify the suitability of batteries, sources etc., The data of the last service shall be stated on the PMI Report Form (Sample enclosed).
- 5.7 Each analyser must be calibrated according to the manufacturer's specification at the beginning and end of each shift. Instrument must be checked against known standard for each alloy type to be inspected during the shift.
- 5.8 Certified samples, with full traceability, of a known alloy materials shall be available for use as a random spot check on the instrument calibration.
- 5.9 The surfaces to be examined shall be prepared by light grinding or abrasive paper and solvent cleaner. Evidence of Arc burn resulting from examination shall be removed by light grinding or abrasive paper.

No permanent marks, which are injurious to the usage of product in service, are acceptable.



ENGINEERS INDIA LIMITED
NEW DELHI

**STANDARD SPECIFICATION FOR
POSITIVE MATERIAL
IDENTIFICATION (PMI) AT
VENDOR'S WORKS**

SPECIFICATION

6-81-0001

Page 4 of 6

REV.

0

- 5.10 Alloy Steel ring type joint Gaskets shall be inspected by using portable X-Ray fluorescence instrument.
- 5.11 Testing shall be done as per the procedures outlined by the manufactures of alloy analyser being used. Modification of these procedures if any, must be approved by Owner/EIL.
- 5.12 The persons performing PMI shall demonstrate their capabilities to the satisfaction of Owner/EIL/TPI visiting engineer. If the vendor has qualified operator on their rolls, he may perform the examination. Otherwise PMI examination shall be sub-contracted to an independent testing agency approved by EIL.
- 5.13 Whenever material is identified as not meeting requirements by the visiting engineer a rejection note shall be issued.

6.0 EXTENT OF PMI EXAMINATION

Following sampling plans shall be applicable for PMI examination of various alloy items.

- A. Flanges, Fittings - 100%
Valves, RTJ Gaskets
- B. Pipes - 100% (for pipes procured from traders).

2 random samples drawn from each size/Heat/Lot (for pipes procured directly from Mills).
- C. Fasteners -

<u>Lot Size</u>	<u>Sample Size</u>
Upto 100	2% (Min 2)
101 to 500	1% (Min 3)
501 and above	0.5% (Min 5)

Note:

- a. For Welded Pipes and Fittings, PMI shall be performed on Base Metal as well as weldments.
- b. Whenever any sample drawn to PMI test on the basis of percentage selection in B & C above, fails to meet specification requirements, 100% of items of lot shall be tested for PMI.

7.0 RECORDING AND DOCUMENTATION

The results of PMI examination shall be recorded in a Report Format as enclosed with this specification.

8.0 MARKING

- 8.1 All alloy materials tested by PMI shall be identified using either of the following methods by indicating "PMI OK"
 - a) Bar Code/Hologram Sticker
 - b) A low stress stamp marking



The drawing, design and details given on this format are the property of ENGINEERS INDIA LIMITED. They are merely loaned on the borrower's express agreement that they will not be reproduced, copied, exhibited or used, except in the limited way permitted by a written consent given by the lender to the borrower for the intended use.

POSITIVE MATERIAL IDENTIFICATION REPORT BULK MATERIALS					Page of
Project:	Client				Job No.
PMI Report No.	Vendor/Sub-Vendor				
Purchase Order No.	Testing Agency				
Purchase Requisition No:	PMI Location				
Bulk Item Type (as per Requisition)					
Material Specification/Grade					
Number of items in Lot					
Requisition Item No./ Description	Alloy content, Weight Percent				Remarks Accept/Reject
Element	Cr	Mo	Ni	V	
Specified Range					
Actual observations					
1.					
2.					
3.					
4.					
5.					
6.					
7.					
8.					
Instrument Type / ID					
Last Service Date	Inspection Agency				Witnessed By



ENGINEERS INDIA LIMITED
NEW DELHI

**STANDARD SPECIFICATION FOR
POSITIVE MATERIAL
IDENTIFICATION (PMI) AT
VENDOR'S WORKS**



SPECIFICATION

6-81-0001

REV.

0

Page 6 of 6

Plant PPU & CDW	Client IOCL, PANIPAT REFINERY	Contract Code RHQ, EPCM-3 (P-25)	Document ID 6746-PDM-000-BD-0002	Contract No. 66-6746
	Vendors Documentation Procedure			

VENDORS DOCUMENTATION PROCEDURE

EPCM SERVICES FOR



POLYPROPYLENE & CATALYTIC DEWAXING UNIT

AT PANIPAT

<p>tkIS India / Vendor</p> <table style="width: 100%; border-collapse: collapse;"> <tr><td style="width: 15%; text-align: center;">Category Codes (Submission Purpose)</td><td style="width: 5%; text-align: center;"><input type="checkbox"/></td><td style="width: 5%; text-align: center;">1</td><td>For Approval</td></tr> <tr><td></td><td style="text-align: center;"><input type="checkbox"/></td><td style="text-align: center;">2</td><td>For Review / Comments</td></tr> <tr><td></td><td style="text-align: center;"><input type="checkbox"/></td><td style="text-align: center;">3</td><td>For Information</td></tr> <tr><td></td><td style="text-align: center;"><input type="checkbox"/></td><td style="text-align: center;">4</td><td>For Engineering</td></tr> <tr><td></td><td style="text-align: center;"><input type="checkbox"/></td><td style="text-align: center;">5</td><td>For Enquiry</td></tr> <tr><td></td><td style="text-align: center;"><input type="checkbox"/></td><td style="text-align: center;">6</td><td>For Order Placement</td></tr> <tr><td></td><td style="text-align: center;"><input type="checkbox"/></td><td style="text-align: center;">7</td><td>Final & Approved</td></tr> <tr><td></td><td style="text-align: center;"><input type="checkbox"/></td><td style="text-align: center;">8</td><td>Released for Construction</td></tr> </table> <hr/> <table style="width: 100%; border-collapse: collapse;"> <tr><td style="width: 15%; text-align: center;">Acceptance Codes (Approval Codes)</td><td style="width: 5%; text-align: center;"><input type="checkbox"/></td><td style="width: 5%; text-align: center;">1</td><td>Approved</td></tr> <tr><td></td><td style="text-align: center;"><input type="checkbox"/></td><td style="text-align: center;">2</td><td>Approved for Manufacturing / Fabrication with Comments as marked</td></tr> <tr><td></td><td style="text-align: center;"><input type="checkbox"/></td><td style="text-align: center;">3</td><td>Not Approved / Resubmit</td></tr> <tr><td></td><td style="text-align: center;"><input type="checkbox"/></td><td style="text-align: center;">4</td><td>Retained for Information / Records</td></tr> <tr><td></td><td style="text-align: center;"><input type="checkbox"/></td><td style="text-align: center;">5</td><td>Reviewed</td></tr> <tr><td></td><td style="text-align: center;"><input type="checkbox"/></td><td style="text-align: center;">6</td><td>Reviewed as Noted / Resubmit</td></tr> </table> <p>Remarks for AC2 : This marked-up drawings is hereby approved for fabrication / manufacturing and shall be re-submitted after revision. This drawing should be revised only to the extent of tkIS India / Owner / Client comments. Any other changes made by you will not be considered unless clearly highlighted in covering letter asking for approval.</p> <p>This approval / review does not absolve the supplier from the full responsibility for design and fabrication.</p> <p>Date : ___/___/___ Name : _____</p>	Category Codes (Submission Purpose)	<input type="checkbox"/>	1	For Approval		<input type="checkbox"/>	2	For Review / Comments		<input type="checkbox"/>	3	For Information		<input type="checkbox"/>	4	For Engineering		<input type="checkbox"/>	5	For Enquiry		<input type="checkbox"/>	6	For Order Placement		<input type="checkbox"/>	7	Final & Approved		<input type="checkbox"/>	8	Released for Construction	Acceptance Codes (Approval Codes)	<input type="checkbox"/>	1	Approved		<input type="checkbox"/>	2	Approved for Manufacturing / Fabrication with Comments as marked		<input type="checkbox"/>	3	Not Approved / Resubmit		<input type="checkbox"/>	4	Retained for Information / Records		<input type="checkbox"/>	5	Reviewed		<input type="checkbox"/>	6	Reviewed as Noted / Resubmit	<p>tkIS India / Owner / Client</p> <table style="width: 100%; border-collapse: collapse;"> <tr><td style="width: 15%; text-align: center;">Category Codes (Submission Purpose)</td><td style="width: 5%; text-align: center;"><input type="checkbox"/></td><td style="width: 5%; text-align: center;">1</td><td>For Approval</td></tr> <tr><td></td><td style="text-align: center;"><input type="checkbox"/></td><td style="text-align: center;">2</td><td>For Review / Comments</td></tr> <tr><td></td><td style="text-align: center;"><input checked="" type="checkbox"/></td><td style="text-align: center;">3</td><td>For Information</td></tr> <tr><td></td><td style="text-align: center;"><input type="checkbox"/></td><td style="text-align: center;">4</td><td>For Engineering</td></tr> <tr><td></td><td style="text-align: center;"><input type="checkbox"/></td><td style="text-align: center;">5</td><td>For Enquiry</td></tr> <tr><td></td><td style="text-align: center;"><input type="checkbox"/></td><td style="text-align: center;">6</td><td>For Order Placement</td></tr> <tr><td></td><td style="text-align: center;"><input type="checkbox"/></td><td style="text-align: center;">7</td><td>Final & Approved</td></tr> <tr><td></td><td style="text-align: center;"><input type="checkbox"/></td><td style="text-align: center;">8</td><td>Released for Construction</td></tr> </table> <hr/> <table style="width: 100%; border-collapse: collapse;"> <tr><td style="width: 15%; text-align: center;">Acceptance Codes (Approval Codes)</td><td style="width: 5%; text-align: center;"><input type="checkbox"/></td><td style="width: 5%; text-align: center;">1</td><td>Approved</td></tr> <tr><td></td><td style="text-align: center;"><input type="checkbox"/></td><td style="text-align: center;">2</td><td>Approved for Manufacturing / Fabrication with Comments as marked</td></tr> <tr><td></td><td style="text-align: center;"><input type="checkbox"/></td><td style="text-align: center;">3</td><td>Not Approved / Resubmit</td></tr> <tr><td></td><td style="text-align: center;"><input type="checkbox"/></td><td style="text-align: center;">4</td><td>Retained for Information / Records</td></tr> <tr><td></td><td style="text-align: center;"><input type="checkbox"/></td><td style="text-align: center;">5</td><td>Reviewed</td></tr> <tr><td></td><td style="text-align: center;"><input type="checkbox"/></td><td style="text-align: center;">6</td><td>Reviewed as Noted / Resubmit</td></tr> </table> <p>Date : ___/___/___ Name : _____</p>	Category Codes (Submission Purpose)	<input type="checkbox"/>	1	For Approval		<input type="checkbox"/>	2	For Review / Comments		<input checked="" type="checkbox"/>	3	For Information		<input type="checkbox"/>	4	For Engineering		<input type="checkbox"/>	5	For Enquiry		<input type="checkbox"/>	6	For Order Placement		<input type="checkbox"/>	7	Final & Approved		<input type="checkbox"/>	8	Released for Construction	Acceptance Codes (Approval Codes)	<input type="checkbox"/>	1	Approved		<input type="checkbox"/>	2	Approved for Manufacturing / Fabrication with Comments as marked		<input type="checkbox"/>	3	Not Approved / Resubmit		<input type="checkbox"/>	4	Retained for Information / Records		<input type="checkbox"/>	5	Reviewed		<input type="checkbox"/>	6	Reviewed as Noted / Resubmit
Category Codes (Submission Purpose)	<input type="checkbox"/>	1	For Approval																																																																																																														
	<input type="checkbox"/>	2	For Review / Comments																																																																																																														
	<input type="checkbox"/>	3	For Information																																																																																																														
	<input type="checkbox"/>	4	For Engineering																																																																																																														
	<input type="checkbox"/>	5	For Enquiry																																																																																																														
	<input type="checkbox"/>	6	For Order Placement																																																																																																														
	<input type="checkbox"/>	7	Final & Approved																																																																																																														
	<input type="checkbox"/>	8	Released for Construction																																																																																																														
Acceptance Codes (Approval Codes)	<input type="checkbox"/>	1	Approved																																																																																																														
	<input type="checkbox"/>	2	Approved for Manufacturing / Fabrication with Comments as marked																																																																																																														
	<input type="checkbox"/>	3	Not Approved / Resubmit																																																																																																														
	<input type="checkbox"/>	4	Retained for Information / Records																																																																																																														
	<input type="checkbox"/>	5	Reviewed																																																																																																														
	<input type="checkbox"/>	6	Reviewed as Noted / Resubmit																																																																																																														
Category Codes (Submission Purpose)	<input type="checkbox"/>	1	For Approval																																																																																																														
	<input type="checkbox"/>	2	For Review / Comments																																																																																																														
	<input checked="" type="checkbox"/>	3	For Information																																																																																																														
	<input type="checkbox"/>	4	For Engineering																																																																																																														
	<input type="checkbox"/>	5	For Enquiry																																																																																																														
	<input type="checkbox"/>	6	For Order Placement																																																																																																														
	<input type="checkbox"/>	7	Final & Approved																																																																																																														
	<input type="checkbox"/>	8	Released for Construction																																																																																																														
Acceptance Codes (Approval Codes)	<input type="checkbox"/>	1	Approved																																																																																																														
	<input type="checkbox"/>	2	Approved for Manufacturing / Fabrication with Comments as marked																																																																																																														
	<input type="checkbox"/>	3	Not Approved / Resubmit																																																																																																														
	<input type="checkbox"/>	4	Retained for Information / Records																																																																																																														
	<input type="checkbox"/>	5	Reviewed																																																																																																														
	<input type="checkbox"/>	6	Reviewed as Noted / Resubmit																																																																																																														

00	IFE	Issued for Execution	21.09.21	AKD	21.09.21	PVG / SRA	21.09.21	SAS / MUJ	-
Rev.	Status	Description	Date	Prepared	Date	Checked	Date	Approved	AC
<p>© thyssenkrupp Industrial Solutions (India) Private Limited 2016</p>									Category Code: 3

B 66-6746-10986595 BD 000 00 IA 22.09.2021



Plant PPU & CDW	Client IOCL, PANIPAT REFINERY	Contract Code RHQ, EPCM-3 (P-25)	Document ID 6746-PDM-000-BD-0002	Contract No. 66-6746
	Vendors Documentation Procedure			

Contents:

1.	Scope.....	3
2.	Aim / purpose	3
3.	Abbreviations and Definitions	3
4.	Responsibilities:	4
5.	Procedure: Preparation of Documents	4
5.1	General.....	4
5.2	Document identification and attributes.....	4
5.3	Document layout	5
5.4	Doc-ID code (tkIS document identification number)	5
5.5	Revision index	5
5.6	Contractual language.....	6
5.7	Document formats	6
5.8	Document quality	6
6.	Procedure: Handling of documents and documentation binders	7
6.1	Submission of documents and documentation binders	7
6.2	Guidelines for documentation binders	7
6.3	Guidelines for expediting documents	7
6.4	Guidelines for generation of electronic files	7
6.5	Electronic submission	8
7.	Approvals by tkIS	8
7.1	Category Codes.....	8
7.2	Acceptance Codes	9
7.3	General.....	9
7.4	Documentation binders as part of final inspection.....	9
8.	Structure of documentation binders	9
8.1	Documentation structure for package units and heavy machinery.....	10
8.2	Test Certificates and inspection reports submitted as part of section C.....	11

Attachments and forms:

- Attachment 01: Contract specific requirements
- Attachment 02: Number of copies
- Attachment 03: Instructions for Vendors for submission of drawings / documents electronically to tkIS
- Attachment 04: Structure of documentation binders

Plant PPU & CDW	Client IOCL, PANIPAT REFINERY	Contract Code RHQ, EPCM-3 (P-25)	Document ID 6746-PDM-000-BD-0002	Contract No. 66-6746
	Vendors Documentation Procedure			

1. Scope

This procedure shall apply to the thyssenkrupp Industrial Solutions (India) Private Limited (tkIS-India) and vendors (including project partners) contractually obliged to supply project material and associated drawings, documents including complete set of final documentation for their scope of supply / work for the following contract.

tkIS Contract No.: 66-6746

These requirements shall be practiced for components with equipment number (thyssenkrupp Technical Organisation Number "TON"), material with item number, components with TAG number (electrical / instrumentation material) and completely engineered systems and equipment packages (package units).

These requirements shall not apply to piping components with an item number requiring quality certificates below 3.1 acc. to. EN 10204 and to individually ordered bolts and nuts.

2. Aim / purpose



This procedure shall provide instructions for preparation, handling of Vendor's document, drawings and compiled sets of documentation to facilitate handover of documentation to customer.

This procedure shall guide vendor to follow uniform concepts in addition to the purchase order documents, the "Discipline-Specific Requirements, and technical information requirement indicated in the Technical Specifications / Datasheets.

Purchase order execution shall not be deemed to be complete until after all requirements for the documentation are satisfied.

3. Abbreviations and Definitions

Client	Means recipient of a product, e.g. plant or services (Indian Oil Corporation Limited)
tkIS / tkIS-India/ tkIS-Site	thyssenkrupp Industrial Solutions (India) Private Limited and other offices of tkIS responsible for execution of the project wherever applicable
Vendor / Contractor	Vendor/Contractor shall mean the bidder during the bidding phase and the supplier / contractor after purchase order award. The Vendor supplies the equipment and/or services as specified by tkIS.
Construction Documentation (CD)	The Construction Documentation shall mean latest revisions of vendor's documents required for construction, erection and on-site preservation of equipment / machinery.
Final Vendor Documentation (FD)	The Final Vendor Documentation shall mean latest revisions of vendor's all technical documents (including As-Built - i.e. as fabricated at vendor's works), spare parts lists, list of special tools and other manufacturer instructions / procedures (QA / testing plans / procedures and storage, installation, maintenance, operation instructions etc.).
Manufacturer's Data Report (MDR)	The MDR comprises the quality assurance documentation consisting material test certificates, inspection records / reports, as well as all other reports and certificates as indicated in Order Specification in accordance with sections 8.2 of this document.
Doc-ID Code / Doc-ID Number	tkIS document identification number
Document	Individual document (or Drawing) as described in purchase order, order specifications / data sheets or any other contractual document etc.
Documentation	Documents compiled in files as per the sequence / guidelines given and issued for specific purpose (i.e. "for

Plant PPU & CDW	Client IOCL, PANIPAT REFINERY	Contract Code RHQ, EPCM-3 (P-25)	Document ID 6746-PDM-000-BD-0002	Contract No. 66-6746
	Vendors Documentation Procedure			

TON Construction”) tkIS Technical Organisation Number

4. Responsibilities:

- Project Document Manager / Document Controller:
 - Preparation of Project Documentation Structure in line with the Contract Requirement.
 - Documentation (documents and files) prepared and submitted by TKIS-India / vendors / subcontractors are identified, registered and controlled in the manner defined herein to enable the easy identification and retrieval of documents.
 - To compile documentations according to this procedure.
- Lead Engineers:
 - Checking of documentation structure.
 - Identification of tkIS deliverables against each file / documentation structure defined in documentation structure
 - Approval of final documentation submitted by the vendors / construction sub-contractors.

5. Procedure: Preparation of Documents

5.1 General

Documents shall follow the industry practice for preparation of technical drawings and documents based on relevant standards.

As a rule, a separate document shall be prepared for each itemised Equipment (TON). The presentation of several equipment items with different item numbers in a single document shall not be allowed. Exceptions from this rule are flow diagrams, common arrangement drawings etc. as well as standby machines if these are identical with the main machine (same type, construction, material, dimensions, weight, accessories, connections etc.). For this, conformation is to be obtained from the person In-Charge (i.e. Lead Engineer) before preparation of the drawing / document.

If one TON and/or Item number includes more than one drawing, these additional drawing numbers / document identification numbers shall be listed on the general arrangement drawing. Each of these additional drawings shall contain cross-references to the general arrangement drawing.

All information submitted through Drawings / Documents shall be explicit, rule out misinterpretations and relate to the specific application or operating conditions of the equipment supplied. The number of documents shall be kept to a minimum, i.e. as much information as possible should be incorporated in one document. Exceptionally long documents shall be split into logical parts / sections.



5.2 Document identification and attributes

For the unique identification of a document all documents shall be unambiguously marked by the following information at least.

- tkIS Contract number,
- tkIS Doc-ID code,
- Revision No.

In addition to the above mentioned information for the document identification all documents shall bear

- the document title,
- the vendor Name,
- the purchase order number,
- the applicable TON / TAG / Item / Part Number and its description,
- the revision date,

Plant PPU & CDW	Client IOCL, PANIPAT REFINERY	Contract Code RHQ, EPCM-3 (P-25)	Document ID 6746-PDM-000-BD-0002	Contract No. 66-6746
	Vendors Documentation Procedure			

5.3 Document layout

The drawings / documents shall be prepared using tkIS supplied templates. Vendors shall adopt the native files of the drawing / document templates to the Engineering tool being used for execution. Vendors can use their own title block in addition to the tkIS title block. However to avoid any inconsistency, revision index must be single (Common).

The information for the documents identification and the corresponding attributes as listed in chapter 5.2 shall be mentioned at the specified location in the drawing title-block or on the cover page of the document.).

Alternatively the information listed in chapter 5.2 shall be incorporated with contract-specific mark-up on the first page of the standard document / manual / brochures or typical drawings clearly indicating the exact applicable type / model and/or relevant dimensions.

5.4 Doc-ID code (tkIS document identification number)

All documents to be submitted shall be marked by a defined Doc-ID code pre-determined and given by tkIS. The structure of the Doc-ID shall be as given below;

tkIS Document Numbering - Vendor Documents

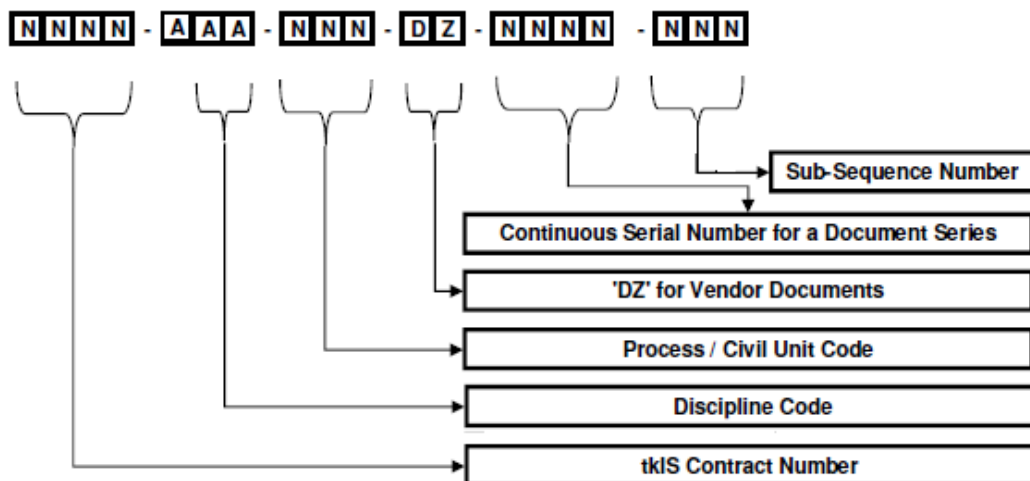

Notes: Discipline and Unit Codes shall be same as per the Technical Specifications. Document Type for Vendor Drawings / Documents shall always be DZ.



The vendor shall submit the “Master Document Index” (list of deliverables) for each of the ordered TON / Item No. to tkIS, immediately after the equipment / item is ordered with the letter-of-intent / purchase order. tkIS shall review this list and inform vendor the vendor document series for each TON / Item No. indicating the tkIS Doc-IDs for the documents listed in Master Document Index. For any new / additional documents vendor shall allocate subsequent incremental sub-serial numbers and update the Master Document Index. Vendor shall indicate the tkIS Doc-ID on all drawings / documents submitted to tkIS. tkIS may reject the drawings / documents submission if the formal aspects are not fulfilled according to this instruction. This Master Document Index shall be submitted by vendor to tkIS along with the monthly status reports.

5.5 Revision index

The revision index shall also be indicated on each document. The level of progress shall be indicated unambiguously by the revision index on the title block.

The first issue of a document shall also indicate the revision index appropriately.

The content of the modification/purpose shall be briefly stated in the revision column. For example the following descriptions shall be used:

Plant PPU & CDW	Client IOCL, PANIPAT REFINERY	Contract Code RHQ, EPCM-3 (P-25)	Document ID 6746-PDM-000-BD-0002	Contract No. 66-6746
	Vendors Documentation Procedure			

Rev. 00 First issue

Rev. 01 tkIS's comments / remarks incorporated

Rev. 02 Renewed submission to comment (approval), point xy

The terms "last revision" or "total revision" shall not be used.

Each document modification and distribution, whether internal for vendor or for external distribution to tkIS, shall increase the revision index by one counter.

All revisions of the Vendor documents shall have passed the Vendor's internal review and approval procedure. The date of review and approval shall be indicated on the document. With this vendor confirms that the documents have been checked for conformance with the requirements of the purchase order documents.

Each revised drawing / document shall be prepared, checked, approved and distributed like the first issue of the document. Each document revision shall be submitted to tkIS only once. While re-submission of the revised documents all triangles and clouds relating to the previous revision shall be removed. In the case of revision, the complete document affected by the revision shall be resubmitted as one pdf document. The submission of part document with specific revised content individually shall not be allowed.

All modifications, contained in the latest revision as compared to the previous one, shall be clearly marked in the document. (The revision index shall be indicated in a triangle following the modification.) Modified parts of a drawing shall be marked by enclosing them in "clouds" with revision index triangle. Any intermediate revisions not submitted to tkIS shall also be submitted for information along with the latest revision. This is to enable tkIS to track changes happened during intermediate revisions. However review of the revised documents shall be limited to the marked revisions and tkIS shall provide approval/comments/receipt-confirmation only on the last revision submitted.

As-Built documents shall not show any revision triangles and clouds and shall be indicated as "As-Built" in the revision index. As-Built Drawings / documents shall be submitted as part of Final Documentation.

5.6 Contractual language

All documents to be submitted shall be prepared in English language. Contract specific requirements if any for translated / bi-lingual documents (i.e. operating and service instructions in local / bi-lingual language) shall be defined in **Attachment 01 "Contract-specific requirements"**.

5.7 Document formats

The sheet sizes of drawings and documents shall correspond to ISO standards generally followed as per the industry practice. The contractual sheet sizes are listed in **Attachment 01 "Contract-specific requirements"**.

Text documents shall generally be prepared in the A4 format. Documents, consisting of several pages shall exclusively include the A4 and/or A3 formats with cover page). Page number and total number of pages shall generally be shown on each page of vendor's documents. As general rule, information on the back side of the document shall not be allowed. Exceptions shall be limited only for standard printed product catalogues, printed manuals or large calculations or voluminous data from a software tool.

All documents greater than A4 shall be folded to A4 so that the title block shall be visible on top. The location of the title block is given in the templates.



All documents, except the reduced sizes of documents which are implemented in the operation- and maintenance instruction, have to be delivered in the original format.

By using colours in documents the substance of information shall not be lost in black and white copies.

5.8 Document quality

Copies of drawings and documents shall be made on white paper on good quality commercially available paper of having minimum thickness of at-least 70g/m² (gsm).

All documents shall have a 2 cm free margin and 4-hole punching. The 4-hole-punched paper of documents greater than A3 shall either be fitted with hole reinforcements or adhesive reinforcing strips.

Plant PPU & CDW	Client IOCL, PANIPAT REFINERY	Contract Code RHQ, EPCM-3 (P-25)	Document ID 6746-PDM-000-BD-0002	Contract No. 66-6746
	Vendors Documentation Procedure			

6. Procedure: Handling of documents and documentation binders

6.1 Submission of documents and documentation binders

The number and scope of the documents and documentation binders to be submitted shall be as specified in the "Summary of Engineering Documents" / "Document Request Form" attached to the technical specification of the purchase order. The minimum number of documentation is indicated in Attachment 02 "Number of copies". Each TON of a purchase order requires an independent documentation (per TON at least one binder), exceptions to be advised during Engineering Phase by tkIS.

The vendor shall submit the documents and documentation binders to tkIS at the dates indicated in the said annexure "Summary of Engineering Documents" / "Document Request Form" to ensure further engineering and proper review and/or forwarding.

Documents and documentation binders shall be submitted with an accompanying letter (transmittal), which shall contain:

- tkIS Contract number, Transmittal-ID
- tkIS Doc-ID Code, Revision No., Document title of the attached documents / documentation binders
- The purpose of transmission ("for information/action", "for review", "for approval"),
- and in the case of the submission of documentation binders the purpose of the binders, e.g. "for construction" or "final documentation" etc.

6.2 Guidelines for documentation binders

In order to ensure a uniform appearance of the documentation binders, the vendor shall use binders as specified in **Attachment A01 "Contract-specific requirements"**.

The vendor shall submit the first edition of the documentation binders (one set draft or master file) of the construction/final documentation binders including index to tkIS electronically for approval.

After the review of the construction/final documentation binders tkIS shall provide approval/review comments, the Table of Contents and the spine labels for each approved/commented binders back to the vendor electronically.

Only after tkIS's approval the required number of binders shall be submitted by vendor in line with the Table of Contents (documentation grouping and sequence) and considering tkIS approval/review comments. Direct submission of final copies without approval from tkIS will not be accepted and the vendor will have to submit all required number of binders again after incorporating the changes given by tkIS.

The binders shall only be filled to a maximum level of 90 % to leave space for revisions or amendments. For the delivery of the documentation binders, the binders shall be placed into parcels in suitable position and sent via courier service to the delivery address of the documentation as indicated in **Attachment 01 "Contract-specific requirements"**.



6.3 Guidelines for expediting documents

Expediting documents shall be submitted as specified and must be clearly identified. Material delivery schedules, fabrication and construction time schedules shall be submitted not later than on the date of the first drawing submittal for review. Updated versions shall thereafter be submitted monthly without specific request by tkIS. The expediting document shall show all schedule-critical materials and the critical path, regardless of whether they have been ordered or not. Moreover, the material delivery schedules of subcontractors or manufacturers of key equipment shall be shown. The expediting documents shall show the scheduled completion dates as indicated in the original time schedule and the actual status together with the updated time schedule. Expediting documents are for tkIS's information only.

6.4 Guidelines for generation of electronic files

Documents are exchanged via a Document Collaboration Platform Workspace. Vendor shall submit only soft copies in PDF file format to tkIS. Vendor shall ensure that PDF files shall not be encrypted or password protected to allow access, modification and management.

Native Files shall be submitted only along with Final / As-Built Documentation if required. Native files submission during the engineering phase for approval if any shall be as per the specific instructions of the technical responsible Lead Engineer.

Plant PPU & CDW	Client IOCL, PANIPAT REFINERY	Contract Code RHQ, EPCM-3 (P-25)	Document ID 6746-PDM-000-BD-0002	Contract No. 66-6746
	Vendors Documentation Procedure			

Separate pdf files shall be submitted for each individual documents identified with one Doc-ID Code. Multiple drawings / documents with several Doc-IDs merged to one single pdf file shall not be accepted. All drawings / documents greater than A3 shall have individual single page pdf files with individual Doc-IDs. A4 and A3 size documents can be multi-page pdf files.

The orientation of pdf files shall be in reading orientation for all sizes irrespective of the size of document and number of pages.

Name of the pdf file shall be:

Doc-ID Code_000_Rev.pdf

For Example: 6746-EQS-022-DZ-0003-005_000_04.pdf

Following restrictions shall be taken into account naming of pdf files for electronic transfers.

- Length of file name must not exceed 128 characters. The whole length of path name and file name together must not exceed 200 characters.
- Blanks are not allowed (use underscore “_” instead of blank to separate parts of the file name)
- Special characters (e.g. / , \ , : , * , ? , “ , < , > , !) and umlauts are not allowed

6.5 Electronic submission

Documents are exchanged electronically in pdf format through Document Collaboration Platform Workspace. The Login Credentials for Workspace and Workspace Manual will be provided to the vendor nominated user. Details regarding the handling of the Workspace are described in **Attachment 03**.

Whenever Workspace does not generate automatic intimations to the recipients e-mail intimation shall be sent by the originator to recipient.

E-mail transfer of documents as attachment is not allowed.

Date of receipt of document will be considered only when tkIS can open and view the documents and transmittal properly. If tkIS can't open or view the documents submission will be treated as invalid / void /rejected.

All files submitted as part of Final / As-Built Documentation must be accompanied by a table of contents and a structure description for native files if applicable. (Description of layer allocation, pin allocation, list of fonts applied). The files shall be named according the file naming convention explained in this procedure (refer to chapter 6.4).

7. Approvals by tkIS

tkIS shall review the documents to be submitted by vendor with respect to the requirements specified in the purchase order / technical specifications. tkIS will provide review comments and return the document with acceptance code. The acceptance code will be clearly marked on the in-built CC-AC Code Block or Electronic stamp on the drawings / document.



tkIS shall check/comment the documents within a period of ten (10) working days after receipt. Vendor shall consider this review period in his manufacturing schedule.

Once the commented Documents are received by vendor, Vendor will submit the revised Drawings/ Documents with next revision within a period of ten (10) working days.

7.1 Category Codes

Category Codes are the codes followed to indicate the Document Submission Requirements or the Document Status. Following are the Category Codes;

- 1 for Approval
- 2 for Review / Comments
- 3 for Information
- 4 for Engineering
- 5 for Enquiry
- 6 for Order Placement
- 7 Final & Approved
- 8 Released for Construction

Plant PPU & CDW	Client IOCL, PANIPAT REFINERY	Contract Code RHQ, EPCM-3 (P-25)	Document ID 6746-PDM-000-BD-0002	Contract No. 66-6746
	Vendors Documentation Procedure			

7.2 Acceptance Codes

Acceptance Codes are the codes followed to indicate the Document Approval Status confirmed by the Approving Authority. Following are the Acceptance Codes;

- 1 Approved
- 2 Approved for Manufacturing / Fabrication with comments as marked
- 3 Not Approved / Resubmit
- 4 Retained for Information / Records
- 5 Reviewed
- 6 Reviewed as noted

Note: The Category Codes and Acceptance Codes will be abbreviated in the footer of the Transmittal.

7.3 General

Approval or review of the vendor's drawings and documents, shall not relieve the vendor of his responsibility for the correctness of drawings and documents.

If the vendor starts the fabrication without approved drawings/documents by tkIS he has the full responsibility without releasing him from any obligations e.g. modification or repetition of the work in a later stage after receiving the approval of tkIS. Cost related to consequences due to the start of fabrication without approved documents/drawings shall be borne by the vendor.

If within the period agreed no remark / approval shall be received by the vendor, he shall contact tkIS accordingly in written form.

On the basis of all comments the vendor shall revise the drawings / documents returned to him and resubmit them within the deadline indicated in the purchase order specification. This does not apply to drawings / documents already finally approved.

7.4 Documentation binders as part of final inspection

Final documentation binders are part of successful final inspection by IOCL approved TPIA.

A waiver of inspection with regard to equipment does not include a waiver of inspection of the related documentation.



No purchase order shall be considered completed until data and documents/documentation required by the purchase order have been received by tkIS.

8. Structure of documentation binders

The documentation binders shall be structured in sections A, B and C as described in the following table (CON = Construction Documentation / FIN = Final Documentation, also refer to **Attachment A04 "Structure of the vendor's documentation"**.)

Section A, Design documents

Group No.	Examples for the documents which are part of the defined group no.	Part of Documentation	
		CON	FIN
01	Block diagrams, flow diagrams, piping and instrumentation diagrams (PIDs), process flow diagrams (PFDs), overview diagrams (as applicable)	CON	FIN
02	Foundation data, fixing plate details, anchoring data, mounting details (as applicable)	CON	FIN
03	Overall arrangement diagrams, general arrangement drawings, overall layout, plot plan etc. (as applicable)	CON	FIN
04	Detailed drawings, part lists, detailed assembly drawings, sectional views, calculations (as applicable)	CON	FIN
05	Fabrication instructions / procedures, welding instructions, heat treatment instructions and other fabrication instructions (as applicable)	CON	FIN

Plant PPU & CDW	Client IOCL, PANIPAT REFINERY	Contract Code RHQ, EPCM-3 (P-25)	Document ID 6746-PDM-000-BD-0002	Contract No. 66-6746
	Vendors Documentation Procedure			

06	Packing / transportation, storage and preservation instructions (as applicable)	CON	FIN
07	Electrical and instrumentation documents, switching and control diagrams, interlocking diagrams, wiring / circuit and terminal diagram, hook-ups (as applicable)	CON	FIN
08	Special documents / product catalogues, catalogues of installed single components, hydraulic diagrams (as applicable)	CON	FIN

Section B, Operating and maintenance instructions

Group No.	Current Group Description	Part of Documentation	
09	Installation and erection instructions, sequence of assembly and erection, installation drawings	CON	FIN
10	Operating and maintenance instructions or user manuals incl. recommended spare parts and lubricants	-	FIN
12	Spare Parts List (unpriced)	-	FIN
13	List of Lubricants / Feedstocks	-	FIN

Section C, Fabrication verification and inspection documents



Group No.	Current Group Description	Part of Documentation	
11	Test certificates and inspection reports, fabrication and inspection documents manufacturer's declaration, declaration of conformity, evidence of origin, test reports and material test certificates, tkIS non-conformance report	-	FIN

8.1 Documentation structure for package units and heavy machinery

Package units are understood to mean independent and operative plant sections consisting of several components. As a rule, the PU are designed, manufactured, erected and commissioned as complete units by the manufacturer.

If advised by the responsible lead engineer, documentation structure for these units shall be as follows:

- 1.) All general documents of a package unit (e.g. PIDs of the unit, user instructions of the unit, instrumentation, bulk material, equipment without TON number, etc.) shall be sorted according to the following sections:
 - **Section A, Design documents**
 - **Section B, Operating and maintenance instructions**
 - **Section C, Fabrication verification and inspection documents**
- 2.) The documentation for the individual equipment items within the package unit shall be sorted accordingly as substructure within the package unit documentation or as advised by the responsible Lead Engineer.

Plant PPU & CDW	Client IOCL, PANIPAT REFINERY	Contract Code RHQ, EPCM-3 (P-25)	Document ID 6746-PDM-000-BD-0002	Contract No. 66-6746
	Vendors Documentation Procedure			



8.2 Test Certificates and inspection reports submitted as part of section C

Fabrication verification and inspection documents shall be submitted with a cover sheet and a table of contents including page numbers for a completeness check.

Examples for inspection documents applicable according to Code of Process Vessels and Heat Exchangers belonging to one TON are given below:

- Inspection release note
- Approved QAP / approved-signed test procedures
- Weld plan and WPS/PQR
- Factory acceptance test reports / certificates
- Manufacturer's test certificate, guarantee certificate, certificate of compliance and performance test reports, declaration of conformity etc.
- Statutory / authority approval documents / third party approval records
- Material certificates & material heat charts
- Material traceability lists
- Inspection reports
- Dimensional check records
- UT-test reports
- MP-test reports
- PT-test reports
- X-ray-test reports
- Hydrostatic test reports
- Air test reports
- Record of production test plates
- Records of tube to tubesheet examination
- NDT drawings / logs
- Welds map indicating welders qualification
- Heat treatment diagrams
- Results of corrosion tests
- Evidence of origin
- tkIS non-conformance report
- tkIS quality certificate

Files containing documents with original notified body-sign / stamps (i.e. IBR / CCOE etc.) shall be marked "Original" and to be hand-delivered to tkIS project manager / inspection Lead-Engineer.

Plant PPU & CDW	Client IOCL, PANIPAT REFINERY	Contract Code RHQ, EPCM-3 (P-25)	Document ID 6746-PDM-000-BD-0002	Contract No. 66-6746
	Vendors Documentation Procedure			

Attachment 01: Contract Specific Requirements

Shipping address

Final / As-Built Documentation to be delivered to Client / tkIS-Site at the address given below.

Client / tkIS-India site office (as applicable)	site address will be confirmed later
---	--------------------------------------

Admissible sheet sizes:

- A0 landscape format / separate Doc-ID required per sheet (Exceptional case only)
 - A1 landscape format / separate Doc-ID required per sheet
 - A2 landscape format / separate Doc-ID required per sheet
 - A3 landscape format
 - A4 portrait / landscape format
- For drawing formats larger than A2, a minimum character height of 2.5 mm shall be used.

Contractual language of documentation:

English

Operating manual language:

Contract language (English)

Symbols / units of measurement:



Metric and US units

Types of lever arch files to be used for the documentation:

Black colour File (Folder/Binder), made from plastic or Cardboard laminated with polypropylene film, 4-ring lever arch file (double DIN A5 Cross-wise storage), with edge protection and grip holes (locking eyelets), 70 mm wide (back width), with transparent plastic spine pocket for insertion of interchangeable labels.

Dividers:

Paper weight @ 160g/m²
Dimensions 240mm * 105mm
Colour white



Plant PPU & CDW	Client IOCL, PANIPAT REFINERY	Contract Code RHQ, EPCM-3 (P-25)	Document ID 6746-PDM-000-BD-0002	Contract No. 66-6746
	Vendors Documentation Procedure			

Attachment 02: Number of copies

During engineering approval, the drawings / documents shall be submitted through the Workspace. In addition, hard-copies (paper prints) shall be submitted according to the details indicated below and in line with “Summary of Engineering Documents” / “Document Request Form” attached to technical specification

Minimum number of paper copies of documentation files:

Documentation Type	Number of Sets
draft Construction Documentation (for approval)	Electronic Submission
Construction Documentation (after approval)	6 Hard + 2 Soft Copies Sets to tkIS-Site
draft Final Documentation (for approval)	Electronic Submission
Final Documentation (after approval)	6 Hard + 2 Soft Copies Sets to Client / tkIS-Site as advised.

Plant PPU & CDW	Client IOCL, PANIPAT REFINERY	Contract Code RHQ, EPCM-3 (P-25)	Document ID 6746-PDM-000-BD-0002	Contract No. 66-6746
	Vendors Documentation Procedure			

Attachment 03: Instructions for submission of drawings / documents electronically to tkIS



- Vendor shall submit only soft copies (pdf) to tkIS for review. Hard copies shall be submitted to Client / tkIS-Site only for Construction / Final / As-Built Documentation.
- As far as possible Vendor shall prepare pdf file directly from the source/native file/application. In exceptional cases scanned pdf files shall be accepted. Care shall be taken that electronic file size (Total data size for single pdf file of drawing, document does not exceed 40 MB.
- pdf file of document shall be submitted through the Workspace. Vendor to maintain the Original signed copy as master copy and to be offered for verification for tkIS's / Third party Approval Agency's inspector upon request / during audit.
- Name of the pdf file shall be: Doc-ID_Part_Rev.

For example for Rev.00 Document file name shall be;

NNNN-AAA-XXX-DZ-NNNN-NNN_000_00.pdf

Following restrictions shall be taken into account to avoid problems while transfer of documents through Workspace.

- Length of file name must not exceed 128 characters. The whole length of path name and file name together must not exceed 200 characters.
- Blanks are not allowed (use underscore “_” instead of blank to separate parts of names)
- Special characters (e.g. / , \ , : , * , ? , “ , < , > , !) and umlauts are not allowed
- Documents to be sent to tkIS shall clearly indicate tkIS PO No., TON No., tkIS Document ID, Revision and document description.
- Date of receipt of document shall be considered only when tkIS can open and view the documents. If tkIS can't open or view the document submission will be treated as invalid / void. Vendor shall ensure that pdf files shall not be encrypted or protected.
- After reviewing document tkIS shall return approved/commented documents through Workspace. Once the commented documents are received by vendor, vendor will submit the revised documents with next revision within a period of ten (10) working days. As far as possible vendor shall not change the position of details in the drawing / document in next revision.
- In-case documents are not received back with approval / comments within 2 weeks of submission to tkIS, vendor to send expediting/follow-up mail to tkIS Taskforce e-mail-ID
- Vendor shall maintain document index with tkIS Doc. ID-Code which should also indicate date of submission & date of return. The same shall be sent for tkIS information on monthly interval.

Plant PPU & CDW	Client IOCL, PANIPAT REFINERY	Contract Code RHQ, EPCM-3 (P-25)	Document ID 6746-PMG-000-BD-0004	Contract No. 66-6746
	VENDOR COORDINATION PROCEDURE			

VENDOR COORDINATION PROCEDURE

EPCM SERVICES FOR

POLYPROPYLENE & CATALYTIC DEWAXING UNIT

AT IOCL, PANIPAT

<p>tkIS India / Vendor</p> <table style="width: 100%; border-collapse: collapse;"> <tr><td style="width: 15%; text-align: center;">Category Codes <small>(Submission Purpose)</small></td><td style="width: 5%; text-align: center;"><input type="checkbox"/></td><td style="width: 10%; text-align: center;">1</td><td>For Approval</td></tr> <tr><td></td><td style="text-align: center;"><input type="checkbox"/></td><td style="text-align: center;">2</td><td>For Review / Comments</td></tr> <tr><td></td><td style="text-align: center;"><input type="checkbox"/></td><td style="text-align: center;">3</td><td>For Information</td></tr> <tr><td></td><td style="text-align: center;"><input type="checkbox"/></td><td style="text-align: center;">4</td><td>For Engineering</td></tr> <tr><td></td><td style="text-align: center;"><input type="checkbox"/></td><td style="text-align: center;">5</td><td>For Enquiry</td></tr> <tr><td></td><td style="text-align: center;"><input type="checkbox"/></td><td style="text-align: center;">6</td><td>For Order Placement</td></tr> <tr><td></td><td style="text-align: center;"><input type="checkbox"/></td><td style="text-align: center;">7</td><td>Final & Approved</td></tr> <tr><td></td><td style="text-align: center;"><input type="checkbox"/></td><td style="text-align: center;">8</td><td>Released for Construction</td></tr> </table> <hr/> <table style="width: 100%; border-collapse: collapse;"> <tr><td style="width: 15%; text-align: center;">Acceptance Codes <small>(Approval Codes)</small></td><td style="width: 5%; text-align: center;"><input type="checkbox"/></td><td style="width: 10%; text-align: center;">1</td><td>Approved</td></tr> <tr><td></td><td style="text-align: center;"><input type="checkbox"/></td><td style="text-align: center;">2</td><td>Approved for Manufacturing / Fabrication with Comments as marked</td></tr> <tr><td></td><td style="text-align: center;"><input type="checkbox"/></td><td style="text-align: center;">3</td><td>Not Approved / Resubmit</td></tr> <tr><td></td><td style="text-align: center;"><input type="checkbox"/></td><td style="text-align: center;">4</td><td>Retained for Information / Records</td></tr> <tr><td></td><td style="text-align: center;"><input type="checkbox"/></td><td style="text-align: center;">5</td><td>Reviewed</td></tr> <tr><td></td><td style="text-align: center;"><input type="checkbox"/></td><td style="text-align: center;">6</td><td>Reviewed as Noted / Resubmit</td></tr> </table> <p>Remarks for AC2 : This marked-up drawings is hereby approved for fabrication / manufacturing and shall be re-sbmitted after revision. This drawing should be revised only to the extent of tkIS India / Owner / Client comments. Any other changes made by you will not be considered unless clearly highlighted in covering letter asking for approval.</p> <p>This approval / review does not absolve the supplier from the full responsibility for design and fabrication.</p> <p>Date : ___/___/___ Name : _____</p>	Category Codes <small>(Submission Purpose)</small>	<input type="checkbox"/>	1	For Approval		<input type="checkbox"/>	2	For Review / Comments		<input type="checkbox"/>	3	For Information		<input type="checkbox"/>	4	For Engineering		<input type="checkbox"/>	5	For Enquiry		<input type="checkbox"/>	6	For Order Placement		<input type="checkbox"/>	7	Final & Approved		<input type="checkbox"/>	8	Released for Construction	Acceptance Codes <small>(Approval Codes)</small>	<input type="checkbox"/>	1	Approved		<input type="checkbox"/>	2	Approved for Manufacturing / Fabrication with Comments as marked		<input type="checkbox"/>	3	Not Approved / Resubmit		<input type="checkbox"/>	4	Retained for Information / Records		<input type="checkbox"/>	5	Reviewed		<input type="checkbox"/>	6	Reviewed as Noted / Resubmit	<p>tkIS India / Owner / Client</p> <table style="width: 100%; border-collapse: collapse;"> <tr><td style="width: 15%; text-align: center;">Category Codes <small>(Submission Purpose)</small></td><td style="width: 5%; text-align: center;"><input type="checkbox"/></td><td style="width: 10%; text-align: center;">1</td><td>For Approval</td></tr> <tr><td></td><td style="text-align: center;"><input type="checkbox"/></td><td style="text-align: center;">2</td><td>For Review / Comments</td></tr> <tr><td></td><td style="text-align: center;"><input checked="" type="checkbox"/></td><td style="text-align: center;">3</td><td>For Information</td></tr> <tr><td></td><td style="text-align: center;"><input type="checkbox"/></td><td style="text-align: center;">4</td><td>For Engineering</td></tr> <tr><td></td><td style="text-align: center;"><input type="checkbox"/></td><td style="text-align: center;">5</td><td>For Enquiry</td></tr> <tr><td></td><td style="text-align: center;"><input type="checkbox"/></td><td style="text-align: center;">6</td><td>For Order Placement</td></tr> <tr><td></td><td style="text-align: center;"><input type="checkbox"/></td><td style="text-align: center;">7</td><td>Final & Approved</td></tr> <tr><td></td><td style="text-align: center;"><input type="checkbox"/></td><td style="text-align: center;">8</td><td>Released for Construction</td></tr> </table> <hr/> <table style="width: 100%; border-collapse: collapse;"> <tr><td style="width: 15%; text-align: center;">Acceptance Codes <small>(Approval Codes)</small></td><td style="width: 5%; text-align: center;"><input type="checkbox"/></td><td style="width: 10%; text-align: center;">1</td><td>Approved</td></tr> <tr><td></td><td style="text-align: center;"><input type="checkbox"/></td><td style="text-align: center;">2</td><td>Approved for Manufacturing / Fabrication with Comments as marked</td></tr> <tr><td></td><td style="text-align: center;"><input type="checkbox"/></td><td style="text-align: center;">3</td><td>Not Approved / Resubmit</td></tr> <tr><td></td><td style="text-align: center;"><input type="checkbox"/></td><td style="text-align: center;">4</td><td>Retained for Information / Records</td></tr> <tr><td></td><td style="text-align: center;"><input type="checkbox"/></td><td style="text-align: center;">5</td><td>Reviewed</td></tr> <tr><td></td><td style="text-align: center;"><input type="checkbox"/></td><td style="text-align: center;">6</td><td>Reviewed as Noted / Resubmit</td></tr> </table> <p>Date : ___/___/___ Name : _____</p>	Category Codes <small>(Submission Purpose)</small>	<input type="checkbox"/>	1	For Approval		<input type="checkbox"/>	2	For Review / Comments		<input checked="" type="checkbox"/>	3	For Information		<input type="checkbox"/>	4	For Engineering		<input type="checkbox"/>	5	For Enquiry		<input type="checkbox"/>	6	For Order Placement		<input type="checkbox"/>	7	Final & Approved		<input type="checkbox"/>	8	Released for Construction	Acceptance Codes <small>(Approval Codes)</small>	<input type="checkbox"/>	1	Approved		<input type="checkbox"/>	2	Approved for Manufacturing / Fabrication with Comments as marked		<input type="checkbox"/>	3	Not Approved / Resubmit		<input type="checkbox"/>	4	Retained for Information / Records		<input type="checkbox"/>	5	Reviewed		<input type="checkbox"/>	6	Reviewed as Noted / Resubmit
Category Codes <small>(Submission Purpose)</small>	<input type="checkbox"/>	1	For Approval																																																																																																														
	<input type="checkbox"/>	2	For Review / Comments																																																																																																														
	<input type="checkbox"/>	3	For Information																																																																																																														
	<input type="checkbox"/>	4	For Engineering																																																																																																														
	<input type="checkbox"/>	5	For Enquiry																																																																																																														
	<input type="checkbox"/>	6	For Order Placement																																																																																																														
	<input type="checkbox"/>	7	Final & Approved																																																																																																														
	<input type="checkbox"/>	8	Released for Construction																																																																																																														
Acceptance Codes <small>(Approval Codes)</small>	<input type="checkbox"/>	1	Approved																																																																																																														
	<input type="checkbox"/>	2	Approved for Manufacturing / Fabrication with Comments as marked																																																																																																														
	<input type="checkbox"/>	3	Not Approved / Resubmit																																																																																																														
	<input type="checkbox"/>	4	Retained for Information / Records																																																																																																														
	<input type="checkbox"/>	5	Reviewed																																																																																																														
	<input type="checkbox"/>	6	Reviewed as Noted / Resubmit																																																																																																														
Category Codes <small>(Submission Purpose)</small>	<input type="checkbox"/>	1	For Approval																																																																																																														
	<input type="checkbox"/>	2	For Review / Comments																																																																																																														
	<input checked="" type="checkbox"/>	3	For Information																																																																																																														
	<input type="checkbox"/>	4	For Engineering																																																																																																														
	<input type="checkbox"/>	5	For Enquiry																																																																																																														
	<input type="checkbox"/>	6	For Order Placement																																																																																																														
	<input type="checkbox"/>	7	Final & Approved																																																																																																														
	<input type="checkbox"/>	8	Released for Construction																																																																																																														
Acceptance Codes <small>(Approval Codes)</small>	<input type="checkbox"/>	1	Approved																																																																																																														
	<input type="checkbox"/>	2	Approved for Manufacturing / Fabrication with Comments as marked																																																																																																														
	<input type="checkbox"/>	3	Not Approved / Resubmit																																																																																																														
	<input type="checkbox"/>	4	Retained for Information / Records																																																																																																														
	<input type="checkbox"/>	5	Reviewed																																																																																																														
	<input type="checkbox"/>	6	Reviewed as Noted / Resubmit																																																																																																														

0		Issued for information	06/10/21	SRA <i>SRA</i>	07/10/21	MUJ <i>MUJ</i>	07/10/21	MUJ <i>MUJ</i>	-
Rev.	Status	Description	Date	Prepared	Date	Checked	Date	Approved	AC
									Category Code: - 3





Plant PPU & CDW	Client IOCL, PANIPAT REFINERY	Contract Code RHQ, EPCM-3 (P-25)	Document ID 6746-PMG-000-BD-0004	Contract No. 66-6746
	VENDOR COORDINATION PROCEDURE			
				Rev 00 Page 2 of 14

Table of Contents

1	Introduction.....	3
2	PROJECT INFORMATION	4
2.1	Abbreviations and Definitions :.....	5
3	COMMUNICATION.....	5
3.1	COMMUNICATION TITLE : IOCL- PP & CDW.....	5
3.2	tkIS job (Contract No) number	5
3.3	tkIS India's Taskforce Email Id	5
3.4	Communication between IOCL and tkIS India	5
3.5	Attention:	6
3.6	Email Communications Channel:	7
3.6.1	tkIS India:	7
3.6.2	IOCL :	7
3.7	Use of Workspace for Document Exchange:	8
3.8	Correspondence	8
3.9	Correspondence from tkIS India	8
3.9.1	Correspondence between tkIS-India, Vendor / Sub-contractor :.....	8
3.9.2	Telephone Notes:	9
4	PROJECT CO-ORDINATION.....	10
4.1	Project Management	10
4.2	KICK-OFF MEETING:.....	10
4.3	PROJECT SCHEDULE:	11
4.4	REVIEW MEETINGS:	11
2.1	PROGRESS REPORTING:	11
5	QUALITY ASSURANCE PLAN.....	13
Annexure	14

Plant PPU & CDW	Client IOCL, PANIPAT REFINERY	Contract Code RHQ, EPCM-3 (P-25)	Document ID 6746-PMG-000-BD-0004	Contract No. 66-6746	
	VENDOR COORDINATION PROCEDURE				
					Rev

1 Introduction



Indian Oil Corporation Limited (IOCL) is India's flagship national oil company with business interests straddling the entire hydrocarbon value chain – from Refining, Pipeline transportation and Marketing of petroleum products to exploration & production of crude oil & gas, marketing of natural gas and petrochemicals. It is the leading Indian corporate in the Fortune 'Global 500' listing, ranked at the 151st position in the year 2020.

IOCL is planning for increase in capacity of its Panipat Refinery from existing 15 MMTPA to 25 MMTPA. Expansion Project named P-25 consists of various units. The implementation of P-25 expansion project is planned through 3 consultants viz. PMC/EPCM-1, EPCM-2 & EPCM-3.

tkIS-India has been appointed as consultant for EPCM-3 for execution of CDW/LOBS Unit and a Polypropylene unit inclusive of related Sub-stations, SRRs and other facilities, all on conventional mode.



Sr No	Process Unit	Indicative Capacity
1	Poly Propylene Unit	450 kTPA
2	Catalytic Dewaxing Unit	560 kTPA

The broad scope of activities covered under the purview of EPCM services are Project Management, Consistency Check, Updating BDEP, Preparation of FEED, Residual Process Design / Engineering, Detailed Engineering/ Review of Detailed Engineering, Procurement and Expediting Services, Tendering & Award, Construction Management & Supervision and Assistance in Start-Up, Commissioning & Performance Run Tests for both units.

Plant PPU & CDW	Client IOCL, PANIPAT REFINERY	Contract Code RHQ, EPCM-3 (P-25)	Document ID 6746-PMG-000-BD-0004	Contract No. 66-6746
	VENDOR COORDINATION PROCEDURE			

2 PROJECT INFORMATION

Particulars	Description
Project Title	EPCM # 3 – Polypropylene and Catalytic Dewaxing Unit
Owner / Client	INDIAN OIL CORPORATION LTD. (IOCL) SCOPE Complex, Core-8, 3 rd Floor 7- Institutional Area, Lodhi Road, New Delhi-110003, Tel. No: 011- 2436 7186
Plant Capacity	Polypropylene Unit – 450 kTPA Catalytic Dewaxing Unit – 560 kTPA
EPCM Services Consultant	thyssenKrupp Industrial Solutions (I) PVT. LTD (tkIS India) 6th floor, Tower “C”, Panchshil Business Park, Baner-Balewadi Road, Pune 411 045, India
Site Location	Panipat Refinery (PR) and Panipat Naphtha Cracker Project (PNCP), At Panipat, State: Haryana PIN: 132 140
tkIS India Contract No.	66-6746
Effective date Of Contract (EDC)	10 th August 2021
Contractual Time of Completion	MC – 35 Months from EDC (10 th July 2024) Start-up & Commissioning – 3 Months from MC (10 th October 2024) Project Closure – 4 Months from Commissioning (10 th February 2025)

Plant PPU & CDW	Client IOCL, PANIPAT REFINERY	Contract Code RHQ, EPCM-3 (P-25)	Document ID 6746-PMG-000-BD-0004	Contract No. 66-6746
	VENDOR COORDINATION PROCEDURE			
				Rev 00 Page 5 of 14

2.1 Abbreviations and Definitions :

The following abbreviations and definitions are used within this instruction:

Tender / Enquiry Specifications (MR)	MR describes the supplies and/or services to be provided by Vendor
Mechanical Catalogue (MC)/ Final Vendor Documentation	The MC comprises the complete final documentation, spare parts lists, list of special tools and other Manufacturer instructions (storage, installation, maintenance, operation etc.) according to the enclosed Table of contents.
Manufacturer's Data Report (MDR) Acceptance Documentation	The MDR comprises the quality assurance documentation, inspection documents as well as all other reports and certificates, according to the enclosed Table of contents.
Doc ID Code/Number	Document Number
Document	Each drawing / document described in specifications
Documentation	Compiled documents according to MC and MDR
TON	tkIS Technical Organization Number (Equipment Tags / Item Codes)

3 COMMUNICATION

3.1 COMMUNICATION TITLE : IOCL- PP & CDW

3.2 tkIS job (Contract No) number

For this Project, tkIS India's Project Number is **66-6746** which shall be quoted in all communications.



3.3 tkIS India's Taskforce Email Id

tkIS India will adopt a Task Force concept for executing this project. A dedicated Project Execution Team will be deployed under the overall control of the Project Manager (PM) to execute the Project.

Taskforce Email Id: tkisindia.ioclp25.epcm3@thyssenkrupp.com

3.4 Communication between IOCL and tkIS India



All email correspondences will be issued from and shall be received at tkIS India Project Task force ID tkisindia.ioclp25.epcm3@thyssenkrupp.com with email Copied to (CC) Project Manager m.joshi@thyssenkrupp.com Also, during any direct important or urgent communications between the two teams, Consultant's TF ID should be kept in CC.

Plant PPU & CDW	Client IOCL, PANIPAT REFINERY	Contract Code RHQ, EPCM-3 (P-25)	Document ID 6746-PMG-000-BD-0004	Contract No. 66-6746
	VENDOR COORDINATION PROCEDURE			

3.5 Attention:

For Letters and Correspondences, all communication between the companies will be addressed to the attention of the following, who will arrange any internal distribution.

A) IOCL, HO (Delhi Office)	:	Kind Attn.:- Mr. S K Das, GM Indian Oil Corporation Ltd Refineries Division SCOPE Complex, Core - 8, 7, Institutional Area, Lodhi Road, New Delhi-110 003 Phone: 91-11-2436 7186 Mobile: 91-9711327315
B) IOCL, Panipat Site Office	:	Kind Attn.:- Shri AP Joshi , GM(PJ) PNCP , Panipat, Haryana-132140 Phone : 0180-2526028 Mobile No.- 9034007608 Email : JOSHIAP@INDIANOIL.IN
C) tkIS India, Pune (HO)	:	Kind Attn.:- Mr. Mandar U Joshi, Project Manager (PM) 6 th floor, Tower "C", Panchshil Business Park, Baner-Balewadi Road, Pune 411 045, India Tel. : 020 4621 1222 Fax : 020 4621 1300 TF Email ID : tkisindia.ioclp25.epcm3@thyssenkrupp.com Email : m.joshi@thyssenkrupp.com
D) EPCM - tkIS India Panipat Site Office	:	To be updated later

Plant PPU & CDW	Client IOCL, PANIPAT REFINERY	Contract Code RHQ, EPCM-3 (P-25)	Document ID 6746-PMG-000-BD-0004	Contract No. 66-6746
	VENDOR COORDINATION PROCEDURE			
				Rev 00 Page 7 of 14



3.6 Email Communications Channel:

3.6.1 tkIS India:

Sr No	Particulars	TO :	CC :
A	Project Management / Technical Matters	tkisindia.ioclp25.epcm3@thyssenkrupp.com	m.joshi@thyssenkrupp.com shirish.saraf@thyssenkrupp.com sushant.kulkarni@thyssenkrupp.com
B	Commercial Matters & Financial Matters	tkisindia.ioclp25.epcm3@thyssenkrupp.com	m.joshi@thyssenkrupp.com shirish.saraf@thyssenkrupp.com sushant.kulkarni@thyssenkrupp.com rajesh.mv@thyssenkrupp.com
C	Procurement Matters	tkisindia.ioclp25.epcm3@thyssenkrupp.com	m.joshi@thyssenkrupp.com shirish.saraf@thyssenkrupp.com sushant.kulkarni@thyssenkrupp.com abhijeet.mithari@thyssenkrupp.com devesh.sharma@thyssenkrupp.com
D	Construction Site Matters	tkisindia.ioclp25.epcm3@thyssenkrupp.com	m.joshi@thyssenkrupp.com shirish.saraf@thyssenkrupp.com sushant.kulkarni@thyssenkrupp.com RCM detailed to be updated later

3.6.2 IOCL :

Sr No	Particulars	TO :	CC :
A.	All Communication concerning to Project	dassk01@indianoil.in	gudipatyrs@indianoil.in gajbhiyemd@indianoil.in bakhetiaa@indianoil.in Nayak_R@INDIANOIL.IN devasthalia@indianoil.in kumar_v@indianoil.in

Plant PPU & CDW	Client IOCL, PANIPAT REFINERY	Contract Code RHQ, EPCM-3 (P-25)	Document ID 6746-PMG-000-BD-0004	Contract No. 66-6746
	VENDOR COORDINATION PROCEDURE			
				Rev 00 Page 8 of 14

3.7 Use of Workspace for Document Exchange:

During engineering approval, the drawings / documents shall be exchanged via a Document Collaboration Platform Workspace. Vendor shall submit only soft copies in PDF file format to tkIS. Vendor shall ensure that PDF files shall not be encrypted or password protected to allow access, modification and management.

Nominated users will get email alert when data is uploaded in the workspace. Further, distribution of documents to the concerned persons shall be done by the user.

tkIS-India shall provide necessary access right to vendor nominated representative.

3.8 Correspondence

- All correspondence shall be in English language.
- All Correspondence shall have specific subject mentioned for ease of Tracking.
- All tkIS India correspondence will be numbered as enumerated hereunder:

3.9 Correspondence from tkIS India

All email correspondence from tkIS India will be issued from tkIS India taskforce email id tkisindia.ioclp25.epcm3@thyssenkrupp.com

All email correspondences will have two signatory. One of them will be Project Manager (and other one will be the designated team member from taskforce who is assigned and responsible for that specific activity. Each correspondence shall contain a relevant subject and shall preferably deal with one subject only.

3.9.1 Correspondence between tkIS-India, Vendor / Sub-contractor :



3.9.1.1 For all correspondence from tkIS-India to Vendor :

tkIS-India standard procedure will be followed for Project Correspondence Numbering.

Transmittals from tkIS-India :

T-6717-PIN-VEN-0001, 0002..... (Transmittal)

tkIS-India will use its standard Document Transmittal system for the issue of all documents / Drawings to Vendors. All Document Transmittals shall be sent by Consultant in soft copy only.

Plant PPU & CDW	Client IOCL, PANIPAT REFINERY	Contract Code RHQ, EPCM-3 (P-25)	Document ID 6746-PMG-000-BD-0004	Contract No. 66-6746
	VENDOR COORDINATION PROCEDURE			
				Rev 00 Page 9 of 14

3.9.1.2 For all correspondence related to Technical Queries :

All correspondence in Letters / E-mails shall be serially numbered and it shall be continuous numbers. Copies of relevant correspondence only shall be marked to the other parties as applicable by the Originator of the correspondence.

All important letters shall be sent in single copy only.

Each correspondence shall contain a relevant subject and project title. Each document shall preferably deal with one subject only.

3.9.1.3 For all correspondence from tkIS-India to Vendor :

Emails & Letters	: E/L-6746-PIN-VEN-XXXX	} Where XXXX is serial no.
Minutes of meeting	: M-6746-PIN-VEN-XXXX	
Transmittal	: T-6746-PIN-VEN-XXXX	



3.9.1.4 Correspondence Between tkIS-India SITE to Vendors / Contractors :

Emails & Letters	: E/L-6746-PINS-VEN-XXXX	} Where XXXX is serial no.
Minutes of meeting	: M-6746-PINS-VEN-XXXX	
Transmittal	: T-6746-PINS-VEN-XXXX	

Post award, copy shall be marked to IOCL for all communications with Vendors / Contractors.

3.9.2 Telephone Notes:

All important and critical discussions between Owner & Consultant involving instructions or decisions shall be confirmed in writing by Letter / E-mail by originating party within 3 working days.

Plant PPU & CDW	Client IOCL, PANIPAT REFINERY	Contract Code RHQ, EPCM-3 (P-25)	Document ID 6746-PMG-000-BD-0004	Contract No. 66-6746	
	VENDOR COORDINATION PROCEDURE				
					Rev

4 PROJECT CO-ORDINATION



4.1 Project Management

- The Project Management Services by Vendor / Contractors shall include all phases of project management like Project Initiation, Planning, Implementation, Monitoring & Controlling and Closure of the Project, so as to achieve the goals set for the Project, with respect to Scope, Cost and Time giving due attention towards Quality and Safety.
- The complete technical & commercial requirements, along with the Detailed Scope of Work and project time schedule, will form the basis for executing the Contract.
- The Vendor / Contractors are required to organize their services in a systematic manner to ensure execution and completion of the Project as per the contractual schedule.
- The Vendor / Contractors are required to submit methodology / procedure of Project Execution plan proposed for the project(s) together with the organizational set up proposed at headoffice and Site separately with bio-data of Key-personnel for approval of OWNER/CONSULTANT. For the exact requirements of qualification & experience of key personnel, refer to relevant clause of SCC.
- Vendor / Contractor shall clearly state the Information Technology (IT) requirements to be followed for the Project along with proposed Softwares.
- All activities to be performed/services to be rendered by Vendor / Contractors shall be monitored by OWNER/ CONSULTANT and will be subject to periodic reviews by OWNER / CONSULTANT. The Vendor / Contractors shall facilitate such reviews / monitoring by OWNER / CONSULTANT

4.2 KICK-OFF MEETING:

Immediately after the award of order, a kick-off meeting will be held within 2 weeks to finalise and establish project execution Modalities and Procedures, Project Coordination Procedure, Project Execution Plan, Billing Milestones, Manpower & Tools that will be utilised by Vendor / Contractors, commitments made by the Vendor / Contractors and subsequent agreements reached between OWNER/CONSULTANT and Vendor / Contractors during negotiation phase.

The kick-off meeting will be attended by key members of OWNER/CONSULTANT and Vendor / Contractors. This meeting will address all critical project execution procedures between OWNER/CONSULTANT, the Contractors and other agencies.

Plant PPU & CDW	Client IOCL, PANIPAT REFINERY	Contract Code RHQ, EPCM-3 (P-25)	Document ID 6746-PMG-000-BD-0004	Contract No. 66-6746	
	VENDOR COORDINATION PROCEDURE				
					Rev

4.3 PROJECT SCHEDULE:

The Overall Project Schedule agreed between OWNER/CONSULTANT and Vendor / Contractors shall be the basis for implementation of the project. The detailed project schedule bar-chart shall be prepared by Vendor within 2 weeks of LOI and submitted to tkIS for approval. The schedule shall be updated on monthly basis unless requested for shorter cut-off period. The Project Schedule shall contain detailed activities at each stage for all the individual components.

4.4 REVIEW MEETINGS:

Vendor shall submit the status & constraints prior to the Review Meeting.

Review meeting shall be held virtually over MS team platform/ tkIS office (during the Engineering Phase) and virtually over MS team platform / tkIS Site office (during the Construction Phase). Time / Date shall be communicated at least 2 to 3 days in advance. Additional review meetings at tkIS / IOCL office may be requested depending on the progress of work.

2.1 PROGRESS REPORTING:



Vendor / Contractor shall submit various reports and provide all requisite details related to project progress in IOCL digital platform E2EPMS (End-To-End Project Management suite) for selected vendor who shall be informed about this during Kick off Meeting. E2EPMS is a digital platform developed by IOCL for effective monitoring and controlling of its projects.

In order to facilitate the data input, Vendor / Contractor shall be provided with unique User ID and Password for regular uploading of data. Owner may issue the predefined formats in excel sheets for guidance, from time to time, to ensure ease in implementation of E2EPMS reporting during various phases of Project execution.

Monthly Progress Report to be uploaded in E2EPMS on or before 20nd of each month with cut-off date of 15th of that month. In case site activities are involved, Progress Report shall include Photographs of ongoing construction / site activities, showing the factual position of the construction activities at site. Photographs from shop progress will be submitted as per progress.

Sample Monthly Progress report format will be handed over to Vendor / Contractor who shall not be provided with access to E2 EPMS during Kick-off meeting.

Sample of Work breakdown structure is shown in the table below:

Plant PPU & CDW	Client IOCL, PANIPAT REFINERY	Contract Code RHQ, EPCM-3 (P-25)	Document ID 6746-PMG-000-BD-0004	Contract No. 66-6746
	VENDOR COORDINATION PROCEDURE			

For Dispatch Clearance-IIIrd Party Inspection Agency issued IR,IRN,photograph,along with all documents ITP in MR are to be submitted to tkIS for final Dispatch by tkIS

Supply:



Work Breakdown Structure (WBS)		
Sr.	Description	Weightage in %
1	Receipt of Drawings	10%
2	Approval of Drawings	15%
3	Subordering of major material	20%
4	Receipt of material (major)	40%
5	Manufacturing Completion	85%
7	Final Inspection & dispatch	90%
8	Receipt at site	95%
9	Final Documentation receipt	100%

Erection and installation at site:

Work Breakdown Structure (WBS)		
Sr.	Description	Weightage in %
1	Construction procedures approved	5%
2	Order placement for Raw Material & Bought-outs.	10%
3	Based on Construction progress	75%
4	Final documentation	5%
5	Contract Closure	5%
6	Overall	100%

The Job must commence & to progress on the basis of Drawings approved by tkIS on Code 1 or Code 2. It is vendor's responsibility to get code 1 approval from tkIS from submission of First issue (Rev 0) of vendors Drawing/ document. To meet the manufacturing schedule, vendor shall visit tkIS office to close all the comments provided by tkIS & to reach Code-1 / Code 2 approval from first issue of drawing. Any delay in manufacturing schedule due to delay in getting drawing approval shall be at the cost and risk of vendor.

Description of Code-1 and Code-2 is described elsewhere in this document.

Plant PPU & CDW	Client IOCL, PANIPAT REFINERY	Contract Code RHQ, EPCM-3 (P-25)	Document ID 6746-PMG-000-BD-0004	Contract No. 66-6746
	VENDOR COORDINATION PROCEDURE			
				Rev 00 Page 13 of 14

The project will be monitored on Overall Schedule Basis.



Vendor is also required to attach relevant copies of Inspection reports, un-priced P.O. copies & Job progress photographs etc. wherever necessary to substantiate progress figures.

Vendor Document control index shall be made part of every monthly progress report showing schedule, actual and forecasted dates of all drawings to be released by vendor. Sample Vendor Document control index is enclosed as ANNEXURE-II. Vendor is requested to prepare the same and submit within 2 weeks of award of contract for tkIS comments.

Sample reporting formats required during engineering & construction phase will be handed over to respective contractors during Kick-off meeting.

5 QUALITY ASSURANCE PLAN

- Vendor / Contractors shall ensure that all stages of the work are controlled in accordance with a Quality system as applicable.
- Vendor / Contractors shall submit detailed Quality Assurance Plan along with Quality Audit Schedule which will be adopted for all stages / types of activities for review / approval by CONSULTANT during Kick off Meeting. QAP's and all other quality procedures (NDE & testing procedures, WPS / PQR) shall be reviewed and approved by IOCL approved TPIA involved in inspection at vendors works appointed by vendor
- Vendor / Contractors / IOCL approved TPIA shall carry out the quality checks as per the requirements and guide lines of the Quality plan agreed during the execution of the work.
- Vendor / Contractors shall forward to OWNER / CONSULTANT / IOCL approved TPIA, for review and approval, the plan describing the responsibility for various activities and technical interfaces, necessary resources required for effective quality checks.
- Vendor / Contractors shall carryout periodic Quality Assurance Audits during engineering as well as construction phase of the Project. Contractors shall submit the schedule for such QA audit for information to OWNER / CONSULTANT. All audit reports and audit closure reports shall be submitted to OWNER / CONSULTANT for information and review. Vendor / Contractors shall carry out changes based on OWNER / CONSULTANT comments / recommendations. Further, OWNER / CONSULTANT shall participate in Vendor / Contractors audits, whenever required.
- OWNER / CONSULTANT shall carry out QA & HSE audits (both Home office & Construction site) as and when required throughout the project duration. Contractors shall carry out changes based on OWNER / CONSULTANT comments / recommendations. Further, CONSULTANT / OWNER shall participate in Contractors audits, whenever required.

Plant PPU & CDW	Client IOCL, PANIPAT REFINERY	Contract Code RHQ, EPCM-3 (P-25)	Document ID 6746-PMG-000-BD-0004	Contract No. 66-6746
	VENDOR COORDINATION PROCEDURE			
				Rev 00 Page 14 of 14

- Vendor / Contractor should provide full co-operation to OWNER / CONSULTANT during all the audits by OWNER / CONSULTANT.
- Facilities at shops / site / engineering office for carrying out quality checks by OWNER / CONSULTANT/ IOCL approved TPIA shall be provided by the Contractors.
- Contractor shall ensure that materials, including pipes and pipe fittings are offered to CONSULTANT for inspection at site as per approved ITP, for which, relevant inspection records are also maintained at site.
- The objective of the quality assurance scheme shall be to ensure conformity of equipment / material / site construction to various standards, specifications/drawings and technical requirements that are being mutually agreed between the Vendor / Contractor and OWNER / CONSULTANT. Quality Assurance System should clearly indicate the organizational approach for quality control and quality assurance of the various equipment/construction activities and also provide a verifiable evidence of the Vendor / Contractor having carried out all the activities laid down in the bid document and the procedure. Such conformity to quality level shall be ensured by controlling the quality level of purchased items at vendor's/sub-vendor's shop/site and shall cover from source surveillance to final inspection.
- Right to Inspect: OWNER / CONSULTANT / IOCL approved TPIA or OWNER's representative and/or other representatives shall be entitled at all time to inspect, examine and test all management, design, development, materials, work and workmanship supplied by Vendor / Contractor or for which Vendor / Contractor is responsible during management, design and development and at any and all places where such management, design, development and/or work is carried on, provided such inspection, examination and testing shall, to extent possible, be carried out in conjunction with Vendor / Contractor's similar activities and, if not, upon prior intimation to CONSULTANT.
- In furtherance of the foregoing, Vendor / Contractor shall arrange for OWNER/CONSULTANT to have access to all the places where design and development are being carried out. Under no circumstances shall Vendor / Contractor deny such access to OWNER/CONSULTANT or OWNER's representative.

Annexure

Annexure – I Sample Vendor Document control index

ANNEXTURE-1 VENDOR DRAWING CONTROL INDEX

		Customer INDIAN OIL CORPORATION LTD. (IOCL)																		
		FOA / LOI																		
		Consultant thyssenKrupp Industrial Solutions (I) PVT. LTD (tkIS India)																		
		Project EPCM # 3 – Polypropylene and Catalytic Dewaxing Unit																		
Sr.No	Document Title	Tag No	Contractor Document No	Vendor Doc No	Status	1 st SUBMISSION				2nd SUBMISSION				3rd :						
						Plan Submittal	FSG		Resubmittal Date	Re	Return Date	Code	Resubmittal Date	Re	Return Date	Code	Resubmittal Date	Re	Return Date	Code
							Submission Date	Re												
1	Vendor Document Control Index	22-P-3603A	6746-EQM-022-D2-0002-001		Intial Submission Pending	09-Aug-22														
2	Pump GA Drawing	22-P-3603A	6746-EQM-022-D2-0002-002		Intial Submission Pending	13-Sep-22														
3	Pump Data Sheet & Performance Curve	22-P-3603A	6746-EQM-022-D2-0002-003		Intial Submission Pending	15-Sep-22														
4	Pump Cross Sectional Drawing	22-P-3603A	6746-EQM-022-D2-0002-004		Intial Submission Pending	31-Aug-22														
5	Piping & Instrumentation Diagram	22-P-3603A	6746-EQM-022-D2-0002-005		Intial Submission Pending	17-Sep-22														
6	Mechanical Seal Drawing	22-P-3603A	6746-EQM-022-D2-0002-006		Intial Submission Pending	31-Aug-22														
7	Seal Plan 538 GA Drawing	22-P-3603A	6746-EQM-022-D2-0002-007		Intial Submission Pending	31-Aug-22														
8	Seal Plan 23 GA Drawing	22-P-3603A	6746-EQM-022-D2-0002-008		Intial Submission Pending	NA														
9	Seal Plan 538 Instrument Datasheet	22-P-3603A	6746-EQM-022-D2-0002-009		Intial Submission Pending	31-Aug-22														
10	Seal Plan 23 Instrument Datasheet	22-P-3603A	6746-EQM-022-D2-0002-010		Intial Submission Pending	NA														
11	Motor GA Drawing	22-P-3603A	6746-EQM-022-D2-0002-011		Intial Submission Pending	06-Sep-22														
12	Motor Datasheet	22-P-3603A	6746-EQM-022-D2-0002-012		Intial Submission Pending	06-Sep-22														
13	Coupling Drawing	22-P-3603A	6746-EQM-022-D2-0002-013		Intial Submission Pending	24-Sep-22														
14	System ITP	22-P-3603A	6746-EQM-022-D2-0002-014		Intial Submission Pending	15-Sep-22														
15	Pump ITP	22-P-3603A	6746-EQM-022-D2-0002-015		Intial Submission Pending	06-Sep-22														
16	Motor ITP	22-P-3603A	6746-EQM-022-D2-0002-016		Intial Submission Pending	06-Sep-22														
17	Commissioning and Mandatory Spare Parts List	22-P-3603A	6746-EQM-022-D2-0002-017		Intial Submission Pending	10-Oct-22														
18	Utility Consumption List	22-P-3603A	6746-EQM-022-D2-0002-018		Intial Submission Pending	10-Sep-22														
19	Lubrication Schedule	22-P-3603A	6746-EQM-022-D2-0002-019		Intial Submission Pending	14-Sep-22														
20	WPS & PQR with Welding Map	22-P-3603A	6746-EQM-022-D2-0002-020		Intial Submission Pending	31-Aug-22														
21	Surface Preparation and Painting Procedure	22-P-3603A	6746-EQM-022-D2-0002-021		Intial Submission Pending	31-Aug-22														
22	Pump Installation, Operation and Maintenance(IOM) Manual	22-P-3603A	6746-EQM-022-D2-0002-022		Intial Submission Pending	27-Aug-22														
23	Storage and Preservation Procedure	22-P-3603A	6746-EQM-022-D2-0002-023		Intial Submission Pending	27-Aug-22														
24	NDE Procedures	22-P-3603A	6746-EQM-022-D2-0002-024		Intial Submission Pending	27-Aug-22														
25	Factory Acceptance Test Procedure	22-P-3603A	6746-EQM-022-D2-0002-025		Intial Submission Pending	27-Aug-22														
26	PMI Procedure	22-P-3603A	6746-EQM-022-D2-0002-026		Intial Submission Pending	27-Aug-22														
27	Instrument Index	22-P-3603A	6746-EQM-022-D2-0002-027		Intial Submission Pending	20-Sep-22														
28	Instrument Datasheet for P&ID	22-P-3603A	6746-EQM-022-D2-0002-028		Intial Submission Pending	20-Sep-22														
29	Manufacturing Data Book(MDB)	22-P-3603A	6746-EQM-022-D2-0002-029		Intial Submission Pending	10-Jun-22														
30	IOM Manual for Motors	22-P-3603A	6746-EQM-022-D2-0002-030		Intial Submission Pending	24-Sep-22														
31	Hydro Test Procedure	22-P-3603A	6746-EQM-022-D2-0002-031		Intial Submission Pending	02-Aug-22														